

ControlSet® MEP-455 Series Spring Return Rotary Electronic Damper Actuator

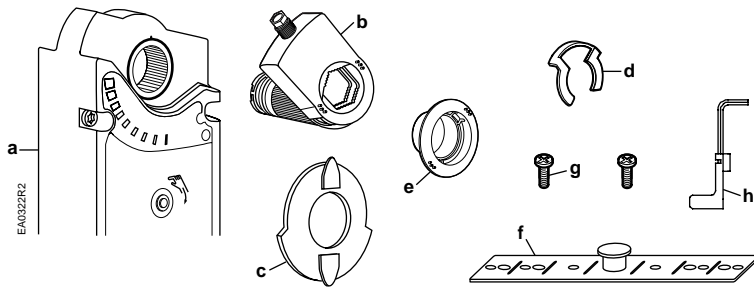

- a. Actuator
- b. Self-centering shaft adapter
- c. Position indicator
- d. Shaft adapter locking clip
- e. Position indicator adapter
- f. Mounting bracket
- g. Mounting screws
- h. 3 mm hex wrench

Figure 1. Parts of the MEP-455 Actuator.



Product Description

These installation instructions describe the steps for direct-coupled mounting of the ControlSet MEP-455 Spring Return Electronic Damper Actuators.

Product Numbers

MEP-455xxx

Warning/Caution Notations

WARNING:		Personal injury or loss of life may occur if you do not perform a procedure as specified.
CAUTION:		Equipment damage or loss of data may occur if you do not follow a procedure as specified.

Required Tools

- 10 mm (13/32-inch) open end wrench
- Drill
- 4 mm (5/32-inch) drill bit
- 3 mm hex wrench (provided)
- Phillips screwdriver
- Marker or pencil

Expected Installation Time

30 minutes

Mounting Positions

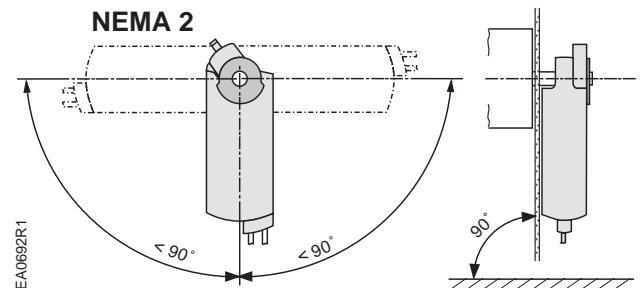

Figure 2. Acceptable NEMA 2 Positions.

Prerequisites

NOTE: The actuator is shipped from the factory with 5° preload. When power is applied to the actuator, the preload is released.

To manually release the preload, insert the 3 mm hex key in the override opening and turn the key in the direction of the arrow. See *Manual Override*.



WARNING:

Do not open the actuator.

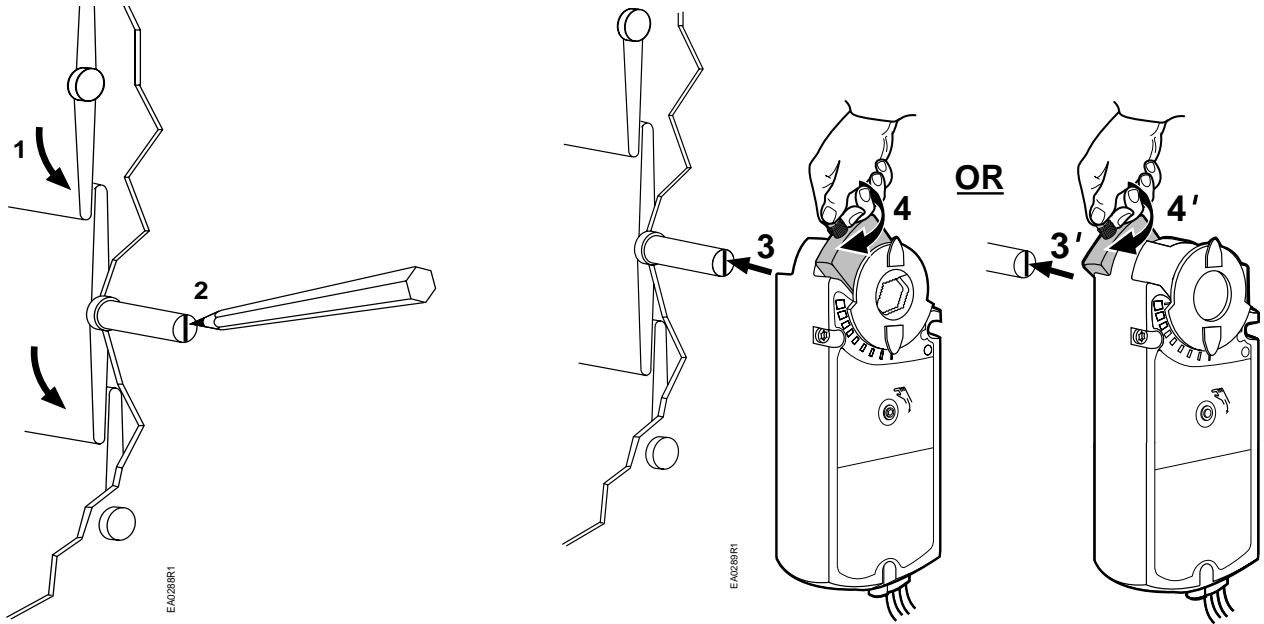

Figure 5. With the Damper Blades in the Desired "0" Position, Place the Actuator on the Shaft.

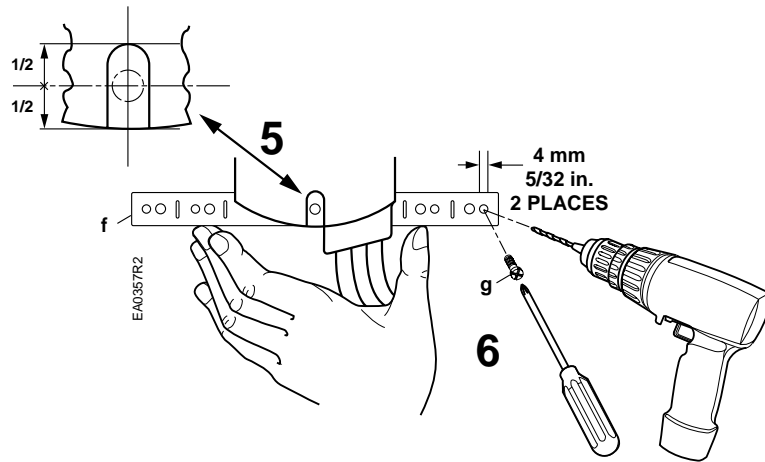

Figure 6. Fasten the Mounting Bracket.

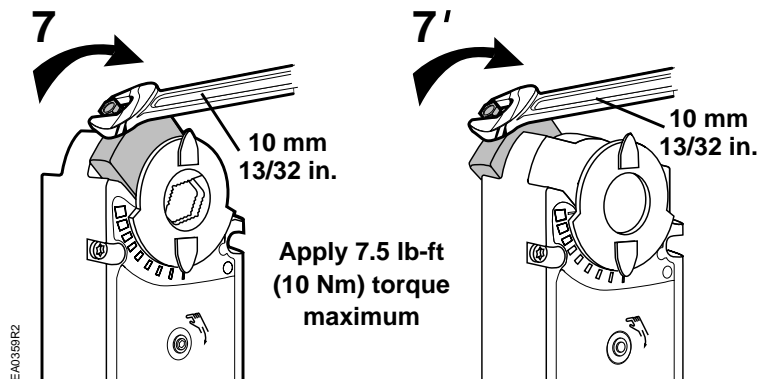

Figure 7. Fasten the Shaft Adapter to the Damper Shaft.

Manual Override

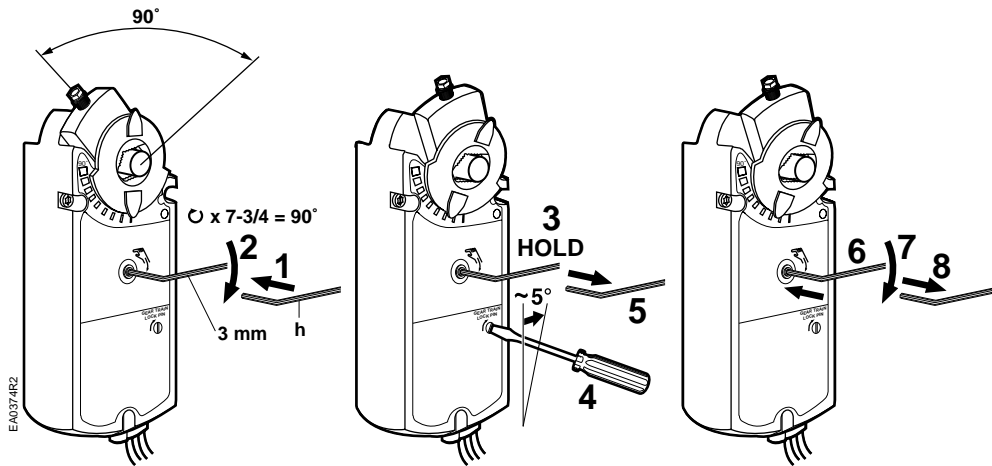

Figure 8. Manual Override.

To use manual override or set preload (See Figure 8)

1. Insert the 3 mm hex key in the override opening. (Step 1)
2. Turn the key in the direction of the arrow on the hand symbol until you reach the desired degree of opening. (Step 2)
3. Hold the key in place. (Step 3)
4. Insert a small flat-blade screwdriver into the gear train lock pin. Turn the screwdriver in the same direction as the arrow until you hear a click or meet slight resistance. (Step 4)

To release manual override or preload (See Figure 8)

1. Insert the 3 mm hex key in the override opening. (Step 6)
 2. Turn the key in the direction of the arrow only a short distance. (Step 7)
 3. Remove the key. (Step 8)
- The actuator will return to "0" position.

NOTE: Applying power and sending a control signal will release manual override.



CAUTION:

When engaging the gear train lock pin, be careful to turn only about 5 degrees until you hear a click or meet slight resistance. Turning too far will strip the lock pin.

5. Remove the key or keep it in place. (Step 5)

Mechanical Range Adjustment

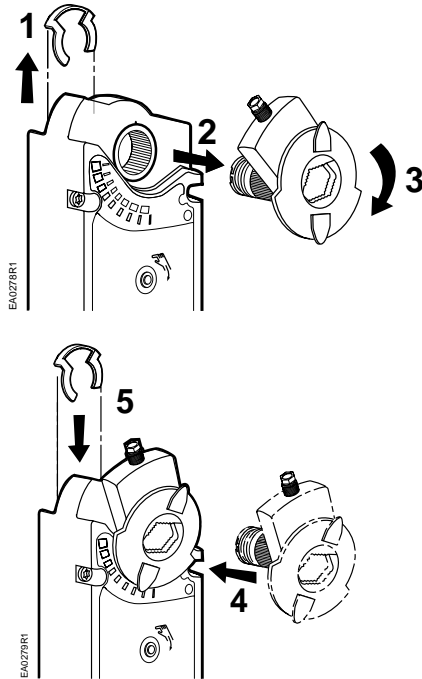

Figure 9. The Angular rotation is adjustable between 0° and 90° at 5 Degree Intervals.

Make sure the actuator is in the zero position when making this adjustment. If making the adjustment before the actuator is in service, take into account the 5° preload. To release the preload, see *Manual Override* section.

Other settings

For adjustment of auxiliary switches and span/offset options, see the individual Technical Instructions. See *References*.

Wiring

All wiring must conform to NEC and local codes and regulations.

Use earth ground isolating step-down Class 2 transformers. Do not use autotransformers.

Determine the supply transformer rating by summing the total VA of all actuators used. The maximum rating for a Class 2 step-down transformer is 100 VA. The recommended maximum actuators shown in Table 1 include a safety factor of 80% of the transformer VA. Operating more actuators requires additional transformers or separate 100 VA power trunks.

Table 1.

Actuator	Power Consumption	Actuators per Class 2 Supply Circuit
Modulating Control		
MEP-4556xx	9 VA	9
Two- and Three-position Control		
MEP-4551xx MEP-455500	8 VA	10



WARNING:

Mixed switch operation is not permitted. To the switching outputs of both auxiliary switches (A and B), only apply:

- Standard cable (250 Vac/24 Vdc)
 - UL/cUL: line voltage, or
 - UL/cUL: Class 2 voltage.

NOTE: Either all six outputs of the dual auxiliary switches must be connected to line voltage or all six outputs must be connected to Class 2 voltage.

Wiring Diagrams

Modulating Control 24 Vac

MEP-4556xx

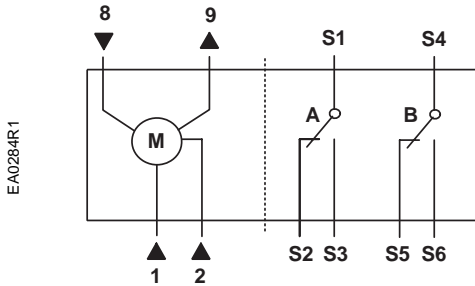

Two-position Control 24 Vac

MEP-455100

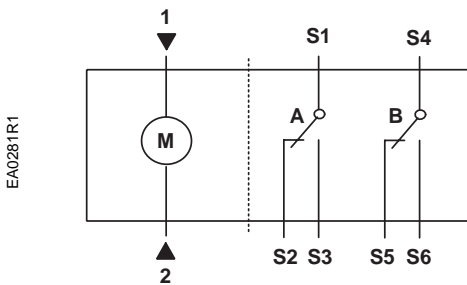

Three-position Control 24 Vac

MEP-455500

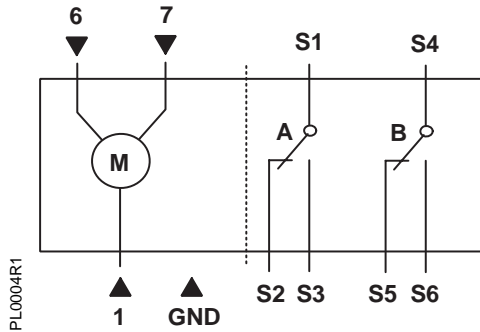

120 Vac Two-position Control

MEP-455300

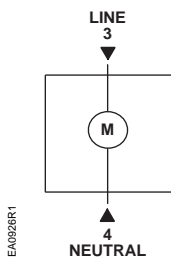

Table 2. 24 Vac Wiring.

Standard Symbol	Function	Terminal Connection	Color
1	Supply (SP)	G	Red
2	Neutral (SN)	G0	Black
6	Control signal clockwise	Y1	Violet
7	Control signal counterclockwise	Y2	Orange
8	0 to 10 Vdc/4 to 20 mA input signal	Y	Gray
9	Output for 0 to 10 Vdc position indication	U	Pink
S1	Switch A Common	Q11	Gray/red
S2	Switch A NC	Q12	Gray/blue
S3	Switch A NO	Q14	Gray/pink
S4	Switch B Common	Q21	Black/red
S5	Switch B NC	Q22	Black/blue
S6	Switch B NO	Q24	Black/pink

Table 3. 120 Vac Two-Position Control.

Standard Symbol	Function	Terminal Connection	Color
3	Line	L	Black
4	Neutral	N	White

Dimensions

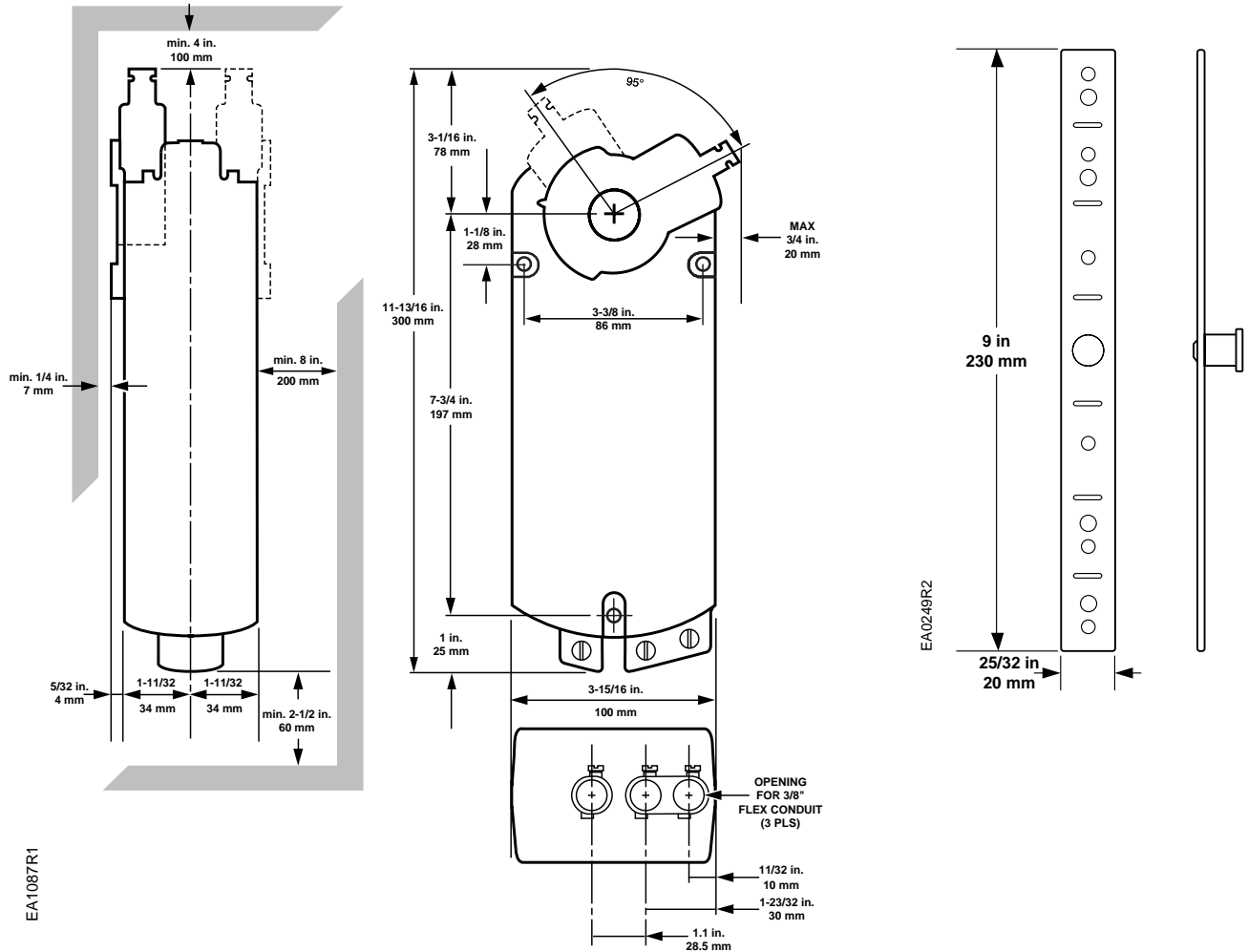

Figure 10. Dimensions of the MEP-455 ControlSet Actuator and Mounting Bracket in Inches (Millimeters).

Information in this publication is based on current specifications. The company reserves the right to make changes in specifications and models as design improvements are introduced. ControlSet is a registered trademark of KMC Controls. Other product or company names mentioned herein may be the trademarks of their respective owners. © 2004 Siemens Building Technologies, Inc.