

# Installation Guide

## Mounting

The CSC-3000 Series are position sensitive. **They must be mounted and calibrated in either the horizontal or vertical plane.**

1. As near to the flow sensor pickup as is feasible, connect the mounting bracket to the mounting surface with two self-threading screws in the two 3/16" (5 mm) mounting holes. Be sure to leave enough room to make connections.
2. Insert the controller, face down, up, right or left. The controller must be installed and adjusted in the same plane or readjustment will be necessary.

## Connections

For all models of the CSC-3000 series, use 1/4" (5 mm) O.D. "FR" tubing on the following push-on fittings:

1. Connect the clean, dry, oil-free main air supply to Port "M" (15 to 30 psi).

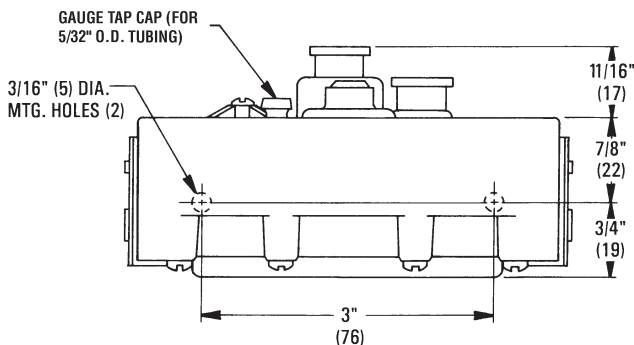
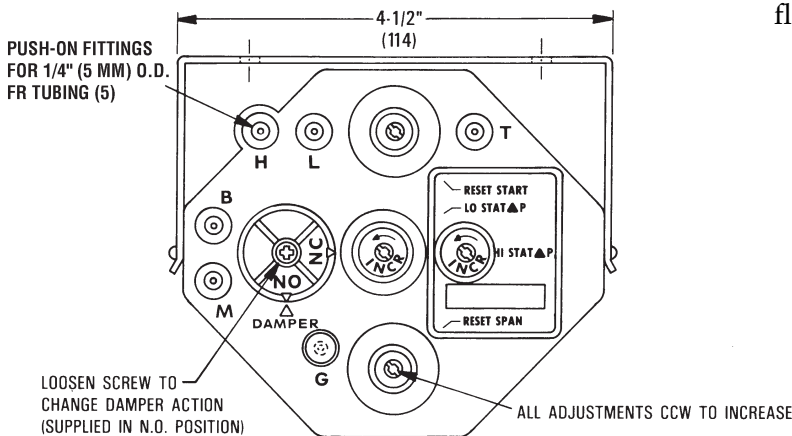

\*(These instructions do **not** apply to the CSC-3014 or the CSC-3501/3505; see their separate Installation Guides.)

2. Connect the damper actuator to Port "B."
3. Connect the thermostat output to Port "T."
4. Connect the high pressure tap on the air flow sensor to Port "H."
5. Connect the low pressure tap on the air flow sensor to Port "L."
6. Check for proper connections. **Make sure all tubes are snug on their fittings.** If loose, trim the end of the tubing and reconnect it to ensure there are no leaks.

**NOTE:** Over time, the tube may stretch or develop microcracks. Trim the end of tube back to undamaged material and reconnect. Replace the tubing if it is brittle or discolored.

**NOTE:** You can easily test for leaks with a squeeze bulb to ensure there are no leaks at the actuator diaphragm or fittings.

7. Use a flow hood or "tee" a Magnehelic® (or equivalent) differential pressure gauge between the controller and the  $\Delta$ P pick-up to determine flow rates.

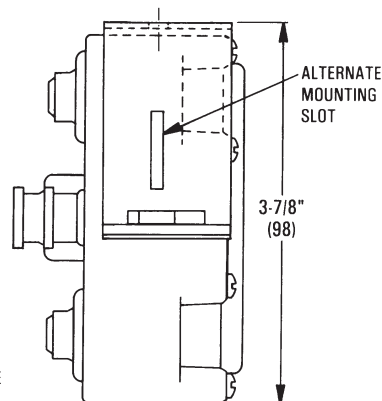

All dimensions are in inches (mm).

## ⚠ CAUTION

**Pneumatic devices must be supplied with clean, dry control air. Any other medium (e.g., oil or moisture contamination) will cause the device to fail.**

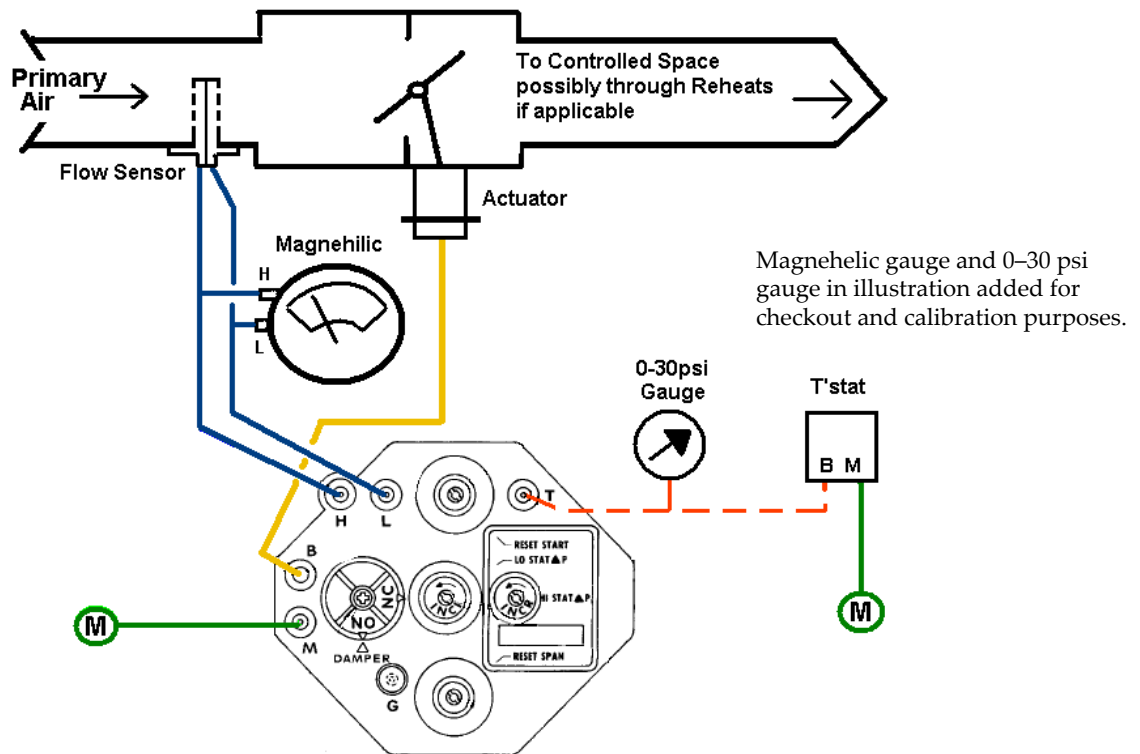

Typical CSC-3011 Application and Connections

## Adjustments and Calibration

### Damper Action

The damper action is factory-set at Normally Open (N.O.). To change to Normally Closed (N.C.), perform the following steps:

1. Loosen the damper selection screw.
2. Turn the selection dial clockwise until the "NC" arrow aligns with the "DAMPER" arrow.

**NOTE: Accuracy in the alignment of the arrows is very important. Make this adjustment as exact as possible.**

3. Tighten the selection screw. **Be sure the screw is tight (2 to 4 in-lbs. of torque), but if overtightened, the plastic will strip out.**

**NOTE:** These instructions do **not** apply to the CSC-3014 or the CSC-3501/3505. See their separate installation guides.

### Determining the Type of Reset

The following table shows when Direct Reset or Reverse Reset is required. Determine the reset type based on the temperature of the primary air entering the VAV box and whether the thermostat in the space is direct or reverse acting.

Primary Air	Thermostat	Reset Type
Cooling	DA	Direct Reset
	RA	Reverse Reset
Heating	DA	Reverse Reset
	RA	Direct Reset

### Adjusting Minimums and Maximums

When adjusting the minimum and maximum flow settings, the output responds slowly to changes in the setpoint. Wait for the flow rate to stabilize after making an adjustment (usually 20 to 30 seconds) before making further adjustments. Also, if the damper position is all the way closed or open when starting this step, turn the adjustment one full turn, and then wait 20 to 30 seconds for a change in the flow reading of the Magnehelic gauge. If no change occurs after this time, repeat until the flow rate changes.

## DIRECT Reset Minimum and Maximum

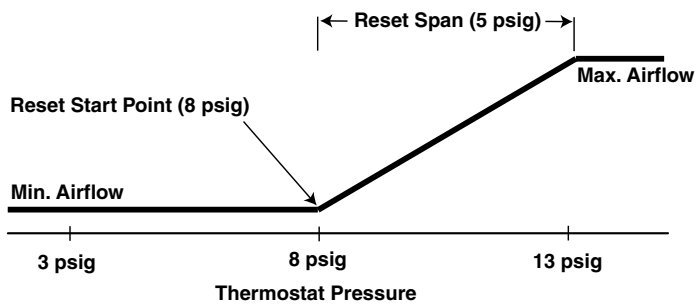

NOTE: The direct reset illustration above assumes no relays are connected between the thermostat and "T" port.

For Direct Reset (DA thermostat for cooling or RA thermostat for heating), perform the following steps:

1. On the CSC-3000, disconnect the "T" port and leave it open.
2. Adjust the LO STAT  $\Delta P$  (center dial) one adjustment at a time until the desired **Minimum** airflow is read at the Magnehelic gauge and is stable.

NOTE: Adjust the dial no more than about a half rotation at a time. After making any adjustment, wait approximately ten seconds while watching for motion in the damper shaft. If no motion occurs, make the next adjustment.

NOTE: **IF the LO STAT  $\Delta P$  Limit must be set at "0" (zero minimum),** see the CSC-3000 Series Applications Guide.

3. Reconnect the thermostat tubing to the "T" port and apply 15 psi or more to the "T" port.
4. Adjust the HI STAT  $\Delta P$  (dial on right) one adjustment (1/4 to 1/2 knob rotation) at a time until the desired **Maximum** airflow is read at the Magnehelic gauge and is stable.
5. Repeat Steps 1 through 4 to verify the settings to be correct and fine tune if necessary.

## REVERSE Reset Minimum and Maximum

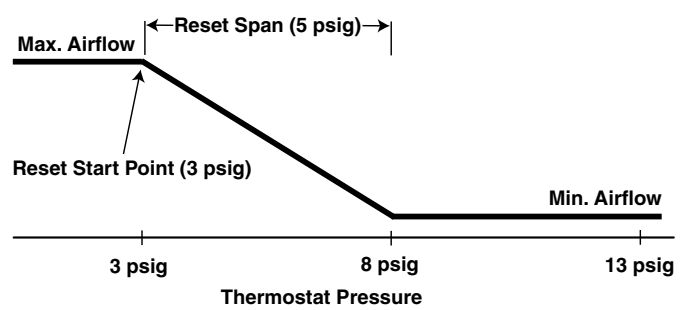

NOTE: The reverse reset illustration above assumes no relays are connected between the thermostat and "T" port.

For Reverse Reset (RA thermostat for cooling or DA thermostat for heating), perform the following steps:

1. On the CSC-3000, disconnect the "T" port and leave it open.
2. Adjust the LO STAT  $\Delta P$  (center dial) one adjustment at a time until the desired **Maximum** airflow is read at the Magnehelic gauge and is stable.

NOTE: Adjust the dial no more than about a half rotation at a time. After making any adjustment, wait approximately ten seconds while watching for motion in the damper shaft. If no motion occurs, make the next adjustment.

3. Apply 15 psi or more to the "T" port.
4. Adjust the HI STAT  $\Delta P$  (dial on the right) one adjustment (1/4 to 1/2 knob rotation) at a time until the desired **Minimum** airflow is read at the Magnehelic gauge and is stable.

NOTE: **IF the HI STAT  $\Delta P$  Limit must be set at "0" (zero minimum),** see the CSC-3000 Series Applications Guide.

5. Repeat Steps 1 through 4 to verify the settings to be correct and fine tune if necessary.

## Reset Start Point

Models of the CSC-3000 series come with reset start points factory-set at 3, 8, or 10 psi. These are standard in most applications and typically do not require adjustment. Leaving this adjustment at the factory setting is recommended.

If a reset start point is needed other than the default setting, all models are field adjustable between 0 and 10 psi. (If the reset start point is changed, the reset span may need to be adjusted as well.) To adjust the reset start point, see the Applications Guide for these controllers.

## Reset Span

The CSC-3000 series controllers are factory set with a reset span of 5 psi. This is standard in most applications and does not typically require adjustment. Leaving this adjustment at the factory setting is recommended.

Reset span is the pressure change at “T” above the reset start point that causes the flow setpoint to move from one extreme to the other. In a direct reset application, the flow setpoint will change from minimum to maximum flow above the start point. In a reverse reset application, the reset will change from maximum to minimum flow above the start point.

If necessary, the reset span can be adjusted. If the reset span is changed, the minimum and maximum flows may need to be readjusted. To adjust the reset span to another value, see the Applications Guide for these controllers.

## Maintenance

No routine maintenance is required. Each component is designed and manufactured for reliability and performance. Careful installation and use will ensure long-term dependability.

### ▲ CAUTION

**Pneumatic devices must be supplied with clean, dry control air. Any other medium (e.g., oil or moisture contamination) will result in the device’s eventual failure.**

## Troubleshooting

**The CSC-3000 series are position sensitive. Be sure to mount the controller with the correct orientation.** See the Mounting section. If the controller is calibrated in a position other than the final mounting position, the calibration (minimum and maximum flow limits) will be off.

The spring range of the actuator does not matter. However, sufficient main air is required to provide the actuator with enough force to operate the damper/linkage. Also, there can be no leaks in the actuator since even small leaks can cause the actuator to not stroke. You can easily test for leaks with a squeeze bulb to ensure there are no leaks at the actuator diaphragm or fittings.

Any sequencing with other controllers, valves, or pneumatic-electric relays must be sequenced with the controller’s reset range, **not** the actuator’s spring range.

These controllers are typically used on single-duct applications but may be found in dual-duct applications. When working on dual-duct applications it may be necessary to work on one duct at a time.

## More Information

For **specifications**, see the CSC-3000 Series Data Sheet. For **additional adjustments, principles of operation, and sample applications**, see the CSC-3000 Series Applications Guide.

This installation guide does **not** apply to the **CSC-3014** (designed to work with CTC-2100 Thermostats) or the **CSC-3501/3505** (Linear Volume Reset Controllers). For those controllers, **see their separate data sheets and installation guides.**

**KMC Controls, Inc.**  
19476 Industrial Drive  
New Paris, IN 46553  
574.831.5250  
www.kmcccontrols.com  
info@kmcccontrols.com