

Applications Guide



Contents

General Information (All Applications)	3
Important Notices	4
Accessories	4
Connection and Configuration	5
Connections	5
External Input (AI1)	5
Change Setpoint	6
Change Configuration	6
Sequences	7
Cross-References	8
CTE-5202 Troubleshooting	11
Display Is Blank	11
Setpoint Is Not Maintained	11
Temperature Reading Is Incorrect	11
Wiring Issues	11
Single-Zone Proportional Heating and Cooling Applications	12
Heating, RA and DA	13
Chilled Beam Cooling	14
Chilled Beam 4-Pipe Heating and Cooling	15
Chilled Beam 2-Pipe Heating and Cooling with Changeover	16
Pressure Dependent VAV Applications with MEP-4xx2	17
Cooling or Heating	18
Auto and Override (to Fully Closed)	19
Other Applications	19

- Pressure Independent VAV Applications with CSP-4702 20**
 - Replacing a CSP-5001/5002.....21
 - Replacing a CEP-4xxx or CSP-40xx/42xx/44xx/46xx or CSE-484x.....22
 - Cooling or Heating.....23
 - Auto and Override (to Fully Open)24
 - Cooling with 3-Stage Reheat25
 - Cooling with 3-Stage Reheat and Night Setback/Setup26
 - Cooling with Heating Changeover27
 - Cooling with Heating Changeover and Electric Reheat28
 - Cooling with Heating Changeover and Hot Water Reheat29
 - Cooling with Hot Water Reheat30
 - Fan Induction with 2-Stage Electric Heat31
 - Dual Duct, Minimum Air from Cold Duct.....32
- Pressure Independent VAV Applications with CSP-5001/5002 33**
 - Cooling or Heating.....34
 - Auto and Override (to Fully Closed or Fully Open).....35
 - Cooling with 3-Stage Reheat36
 - Cooling with 3-Stage Reheat and Night Setback/Setup37
 - Cooling with Heating Changeover38
 - Cooling with Heating Changeover and Electric Reheat39
 - Cooling with Heating Changeover and Hot Water Reheat40
 - Cooling with Hot Water Reheat41
 - Fan Induction with 2-Stage Electric Heat42
 - Dual Duct, Minimum Air from Cold Duct.....43
- Pressure Independent VAV and CAV Applications with CEP/CSP-4000 Series..... 44**
 - 9.1 VDC vs. 24 VAC Power Options45
 - Cooling46
 - Cooling with Morning Warm-Up.....47
 - Cooling with 3-Stage Reheat48
 - Cooling with Heating Changeover49
 - Cooling with Hot Water Reheat50
 - Fan Induction with 2-Stage Electric Heat51
 - Damper Tracking (Master/Slave)52
 - Dual Duct Heating and Cooling VAV53
 - Dual Duct Heat/Cool Constant Volume with Hot Deck Make-Up.....54
- Barber Colman TP-81xx Thermostats Replacement Applications..... 55**
 - TP-8101/8102/8103 Replacement (General)56
 - TP-8101/8102/8103 Replacement with MP-52xx Actuators57
 - TP-8124/8125 Replacement with One or No MP-52xx Actuators.....58
 - TP-8124/8125 Replacement with Two MP-52xx Actuators.....59
- Index..... 60**

General Information

(All Applications)

This document gives schematics of sample (new and retrofit) applications, cross-references, troubleshooting, and other related information.

For **CTE-5202 general mounting and connection details, including power connections and input/output connections**, see the installation guide. For **specifications and other information**, see the data sheet.

The latest support files are always available on the KMC Controls web site (www.kmcontrols.com).

NOTE: The CTE-5202 may not work in all applications as a substitute for other models.



(Shown adjusting the Cooling setpoint— during normal operation, only room temperature is shown in the upper right of the screen)

Specifications, design, and operation are subject to change without notice.









Important Notices

The KMC logo and KMC Controls are registered trademarks of KMC Controls, Inc. Other products and name brands mentioned may be trademarks of their respective companies or organizations.

All rights reserved. No part of this publication may be reproduced, transmitted, transcribed, stored in a retrieval system, or translated into any language in any form by any means without the written permission of KMC Controls, Inc.

The material in this document is for information purposes only. **The contents and the product it describes are subject to change without notice.** KMC Controls, Inc. makes no representations or warranties with respect to this document. In no event shall KMC Controls, Inc. be liable for any damages, direct or incidental, arising out of or related to the use of this document.

Accessories

CSP-4702	Differential pressure VAV controller/actuator	
HMO-1161	Wall plate, allows mounting to horizontal 2 x 4", 4 x 4", or other boxes, light almond	
HMO-1161W	HMO-1161 in white	
HPO-0044	Replacement cover hex screws	
HPO-1161	Foam insulating gasket	
MEP-4xx2	Proportional actuators	
REE-50xx	Electric relay modules, staging and reheat	
STE-140x	Duct temperature (Type III) sensors	
STE-1454/1455	Strap-on temperature (Type III) sensors	
VEB-4xxxxxxx	Valves (with proportional actuators)	

NOTE: See sample applications for additional information.

Connection and Configuration

Connections

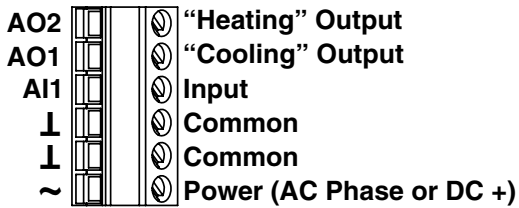

Standard connections to the terminal block are:

- “Heating” output (REE-50xx reheat relay modules and heating valves) to AO2 and ⊥ (Common)
- “Cooling” output (VAV dampers and cooling valves) to AO1 and ⊥ (Common)*
- Changeover (temperature) sensor (Type III, 10K ohm thermistor) and/or standby/unoccupied setback contact to AI1 and ⊥ (Common). (See [External Input \(AI1\) on page 5.](#))
- 24 VAC transformer’s neutral lead to ⊥ (Common) and phase lead to ~. Alternately, 14–35 VDC can be used with + connected to ~ and – connected to ⊥ (Common).

*NOTE: AO1 also controls heating in morning warm-up, changeover, and some other configurations. For examples, see: [Heating, RA and DA on page 13](#), [Chilled Beam 2-Pipe Heating and Cooling with Changeover on page 16](#), [Cooling or Heating on page 18](#), [Cooling with 3-Stage Reheat on page 25](#), [Dual Duct, Minimum Air from Cold Duct on page 32](#), [Cooling with Heating Changeover on page 38](#), [Cooling with Morning Warm-Up on page 47](#), and [TP-8101/8102/8103 Replacement \(General\) on page 56.](#)

NOTE: For additional information on mounting and installation of the CTE-5202, see the installation guide.

External Input (AI1)

Hot/Cold Changeover

For hot/cold air changeover on Sequence 1 or 2, connect a changeover sensor to the AI1 input. The sensor should be a Type III thermistor (10K ohm @ 77° F), such as KMC [STE-140x](#) duct or [STE-1454/1455](#) strap-on sensors. (An internal 10K ohm pullup resistor is provided on AI1.)

See, for example, [Cooling with Heating Changeover on page 27](#) and [Chilled Beam 2-Pipe Heating and Cooling with Changeover on page 16.](#)

At power-up, the default mode for Sequences 1 and 2 is Cold Air mode with a default changeover setpoint of 77° F. If the AI1 sensor reads a temperature higher than 79° F, the Hot Air mode becomes active. Hot Air mode stays active until the AI1 temperature falls below 75° F. Then Cold Air mode is active until the AI1 temperature rises above 79° F, which makes Hot Air mode active. At power-up, if the temperature is between 75° F and 79° F, the thermostat will assume Cold Air mode.

For continuous cold air mode, leave the sensor off.

The changeover temperature setpoint is adjustable between 55 and 85° F in the *ADVANCE* menu, and the default is 77° F. See [Change Configuration on page 6.](#)

Unoccupied/Standby Setback

Contact closure across AI1 and Common initiates the standby setback offset sequence, which causes the cooling setpoint (in all Sequences) to increase and the heating setpoint in Sequence 2 or 3 to decrease by the amount of the setback offset. This setback does not apply during the morning warm-up sequence.

See, for example, [Cooling with 3-Stage Reheat and Night Setback/Setup on page 26](#) and [Cooling with 3-Stage Reheat and Night Setback/Setup on page 37.](#)

Change Setpoint

To change the setpoint:

1. Push the Setpoint button (or either Up/Down button) to display the current value.

NOTE: Sequences 2 and 3 have **two** setpoints indicated by “snowflake/cool” and “fire/heat” icons. When the Cooling setpoint is showing, pushing the Setpoint button will display the Heating setpoint.

2. Use the Up/Down buttons to change the value.
3. Press the Setpoint button again, and the thermostat will control at the new setpoint. (Alternately, after about 30 seconds of no activity, the display reverts back to displaying room temperature.)

NOTE: Setpoint range is 55 to 85° F (13 to 30° C), with a default of 74° (for cooling or 70° for heating).

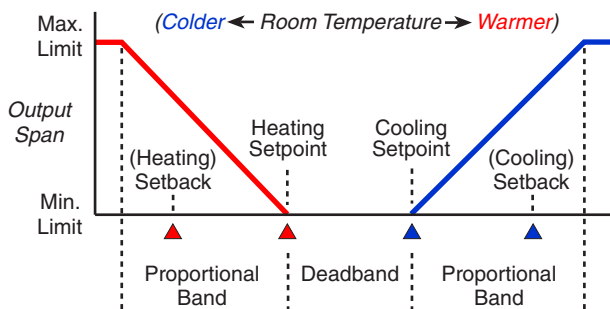

Change Configuration

Press and hold both the Up and Down arrows buttons for about ten seconds until the display starts flashing “LIMITS.”

NOTE: When a menu is **flashing** (*LIMITS*, *ADVANCE*, *SYSTEM*, or *EXIT*), pressing Up or Down displays the next menu item and pressing Setpoint selects that menu. When a menu is **NOT flashing** (e.g., *DEAD BD*), pressing Up or Down changes the value and pressing Setpoint displays the next menu item.

To change any of the **limits (output span)** when “LIMITS” is flashing, press the Setpoint button until the desired limit (*AD1 MIN*, *AD1 MAX*, *AD1 AUX*, *AD2 MIN*, or *AD2 MAX*) is displayed. (Limits are adjustable from 0 to 12 VDC, with *MIN* = 0,

MAX = 12, and *AUX* = 0 as defaults.) Use the Up and Down buttons to change the desired values. (If no Auxiliary Flow is desired, set *AD1 AUX* to 0.)

To change any of the **system or advanced features**, press the Up or Down button until the desired (flashing) *ADVANCE* or *SYSTEM* menu appears and then press the Setpoint button.

The *ADVANCE* menu enables changing (via the Up/Down buttons) the values of:

- *DEAD BD* —Deadband or “minimum setpoint differential” (adjustable from 1 to 10° F, 2° F default)
- *SETBACK* —Standby/unoccupied setback offset (adjustable from 0 to 10° F, 2° F default)—does not apply to morning warm-up
- *PROP BD* —Loop proportional band or “throttling range” (adjustable from 1 to 10° F, 2° F default)
- *Rm OFFSET* —Room temperature offset (adjustable ±5° F, 0 default)
- *ENG OVR* —changeover temperature (adjustable from 55 to 85° F, 77° F default)
- *ITIME* —Loop integral time (adjustable from 0 to 60, 30 minutes default, 0 = cancel integral action)*

The *SYSTEM* menu enables changing:

- Sequence (*SEQ1*, *SEQ2*, or *SEQ3*)—see [Sequences on page 7](#)
- °F (*ENGLISH*) or °C (*METRIC*)
- *BLANK* —Display blanking (*NO* or *YES*)—when blanked, the temperature will display for no more than 30 seconds after a button is pushed

When done, navigate to (flashing) Exit to save changes. **Letting the menu time-out (about 30 seconds) will not permanently save changes.**

***NOTE:** As long as there is an error between room temperature and setpoint, the integral action will cause the output to integrate up or down. *ITIME* is the time it takes the integral action to repeat the effect of the proportional action.

Sequences

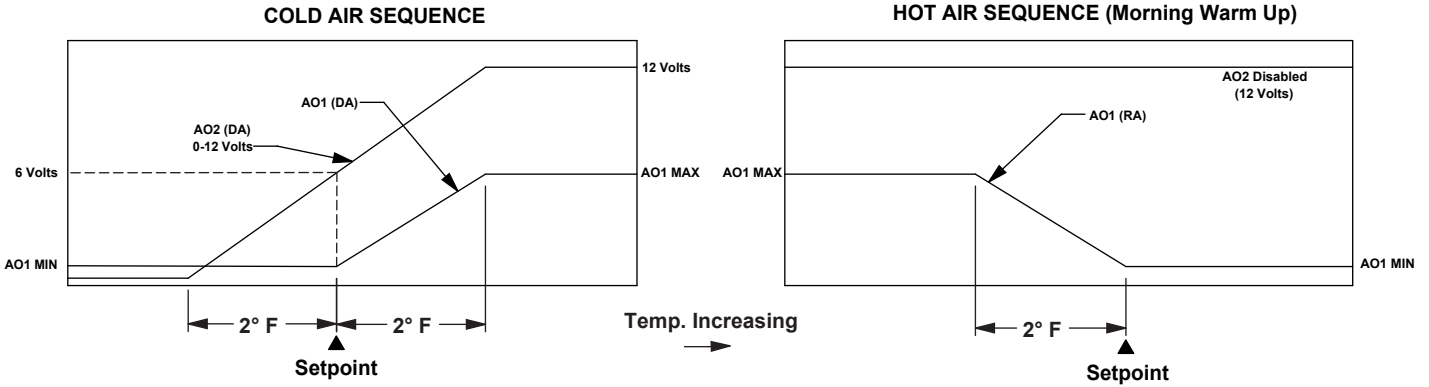

SEQUENCE 1: Single Duct Cooling, Fan Box (with REE-5002 or REE-5017)

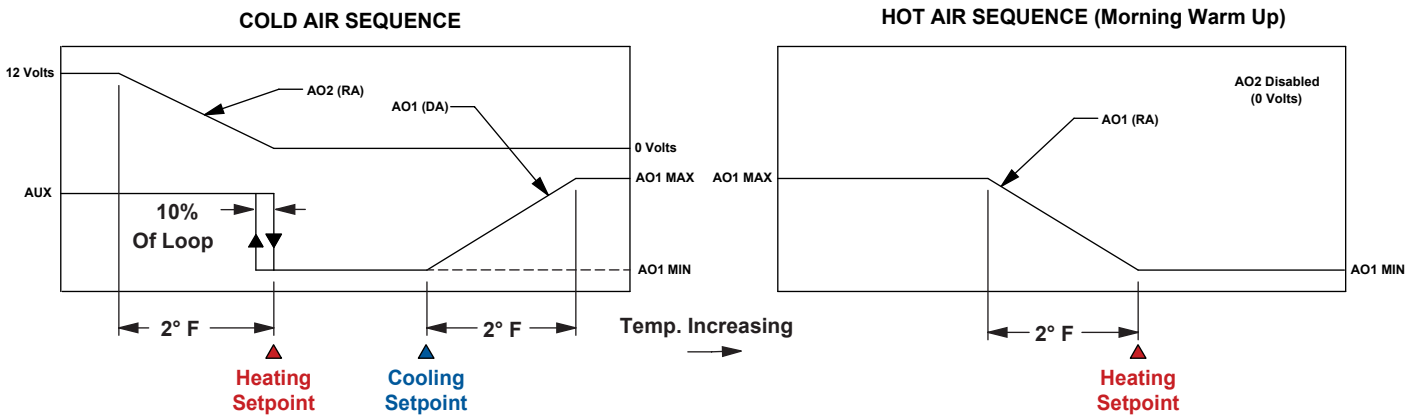

SEQUENCE 2: Single Duct Cooling with Reheat and Auxiliary Flow

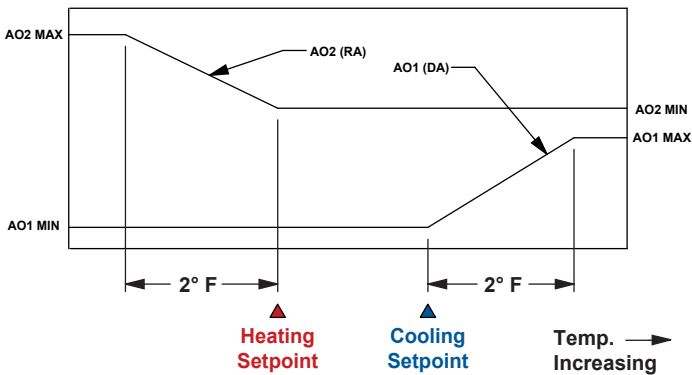

**SEQUENCE 3:
Independent Heating and Cooling Control
(Dual Duct VAV, Baseboard, Single Zone AHU)**

NOTE: AO1 is typically used to control the **cooling** output (primary air damper or cooling valve), and AO2 is used to control the **heating** output (VAV reheat or heating valve).

Cross-References

Barber Colman (TAC, Invensys, Schneider Electric) Thermostat Replaced		CTE-5202 Sequence Selected
TP-8101, TP-8102, and TP-8103		#1
TP-8124 and TP-8125		#3
For wiring and sample applications, see Barber Colman TP-81xx Thermostats Replacement Applications on page 55 .		

Other third-party thermostats that the CTE-5202 can be a functional/upgrade replacement for include:

- Honeywell TB7980 (check application and specifications)
- Johnson Controls (various—check application and specifications)
- Kele RTC-2P (with one or less remote inputs—check application and specifications)
- PEKO (various—check application and specifications)

- Siemens (various—check application and specifications)

- Viconics (various—check application and specifications)

NOTE: Products and name brands here may be trademarks of their respective companies.

NOTE: The CTE-5202 may not work in all applications as a substitute for other models.

(Discontinued) KMC CTE-50xx Thermostat Replaced		CTE-5202 Sequence Selected	Example Replacement Applications
CTE-5001/5011*		#1	See page 46 and page 49 (9.1 VDC)
CTE-5002/5012*		#2	See page 48 (9.1 VDC)
CTE-5003/5013*		(No Replacement)	(9.1 VDC)
CTE-5006/5016**		#2	See page 36 (16 VDC)
CTE-5015**		#1	See page 34 (16 VDC)
*NOTE: These models require a power supply of 9.1 VDC, typically supplied by a CEP/CSP-4xxx controller/actuator, and they have a 0–6 VDC output range. See the discussion on 9.1 VDC power under the CTE-1x0x cross-reference NOTE on page 9 . Need for the REE-1014 in applications is eliminated.			
**NOTE: These models require a power supply of 14–20 VDC, typically using the 16 VDC power supplied by a CSP-5001/5002 controller/actuator. The CTE-5202 can use the same 16 VDC power (or 14–35 VDC or 24 VAC).			

CTE-50xx Terminal Equivalents									
CTE-50xx Terminal	CTE-5001	CTE-5002	CTE-5006	CTE-5011	CTE-5012	CTE-5016	CTE-5015	Description	CTE-5202 Terminal
A	X	X	X	X	X	X		Output: Usually for heating but varies according to model (see the model's installation guide)**	AO1 or AO2*
B	X	X	X	X	X	X	X	Ground reference	⊥ (Common)
C	9.1	9.1	16	9.1	9.1	16	16	+ VDC power supply input	~ (Phase)
D	X	X	X	X	X	X	X	Output: Usually for cooling but varies according to model (see the model's installation guide)**	AO1 or AO2*
E	X	X	X	X	X	X		Output: Varies according to model (see the model's installation guide)	AO1 or AO2*
F	X	X	X	X	X	X		For optional CFM readout.	(Unsupported)
*AO1/AO2 connection is dependent on application and selected configuration. See Connection and Configuration on page 5 , the CTE-50xx Thermostat Replaced chart above, and relevant application section.									

CTE-1xxx Thermostat Replaced 						CTE-5202 Sequence Selected	Example Replacement Applications
KMC / Nailor / Dynacon*	Anemostat (East/West)*	Metal Industries*	Metalaire*	Nailor*	ASC / Titus*		
CTE-1001	13-27, 004100				10027401	#1	See page 46
CTE-1002						#3 (disregard cooling setpoint) or #1 (with 8K–10K ohm resistor for RA mode)	
CTE-1003	13-29	01EC-2146		B3-3001-015 or B3-015		#3	
CTE-1004	13-28	01EC-2129	THM1004		10027403	#2	See page 48 and page 50
CTE-1005			THM1005			#1 (setback used for night setpoint)	
CTE-1008**						#1 (setback used for day setpoint)	
CTE-1101	004643		THM1101		10027415	#1	See page 46 , page 51 , and page 52
CTE-1103		01EC-9229	THM1103		10027411	#1 (single duct) or #3 (dual duct)	See page 49 , page 53 , and page 54
CTE-1105			THM1105		10027413	#1	
CTE-1108**						#1 (setback used for day setpoint)	

***NOTE:** CTE-1x0x thermostats require a power supply of **9.1 VDC**, typically supplied by a CEP/CSP-4xxx controller/actuator, and they have a 0–6 VDC output range. The CTE-5202 can also operate on the 9.1 VDC power supplied by CEP/CSP-4xxx controller-actuators, but the CTE-5202's outputs will be reduced to a maximum of about 5.3 VDC (or a maximum of about 2000 fpm from the CEP/CSP-4xxx). In almost all such applications, this is adequate. In a rare application that requires a full 6 VDC output (or 3000 fpm maximum from the CEP/CSP-4xxx), the CTE-5202 can be powered by the 24 VAC transformer, which can be easily done by switching the wire from Terminal #5 (+9.1 VDC) to Terminal #10 (24 VAC, phase) on the CEP/CSP-4xxx. See [9.1 VDC vs. 24 VAC Power Options on page 45](#). See also the [CEP-4000 Applications Guide](#).

****NOTE:** Discontinued KMC models.

CTE-1xxx Terminal Equivalents												
CTE-1xxx Terminal	CTE-1001	CTE-1002	CTE-1003	CTE-1004	CTE-1005	CTE-1008	CTE-1101	CTE-1103	CTE-1105	CTE-1108	Description	CTE-5202 Terminal
T3	X		X	X	X	X	X	X	X	X	Upper setpoint output without limits	AO1 or AO2*
R1	X		X	X	X	X	X	X	X	X	T1 override	(Unsupported)
T1	X		X	X	X	X	X	X	X	X	Upper setpoint output with limits	AO1*
+	X	X	X	X	X	X	X	X	X	X	9.1 VDC power supply input	~ (Phase)
A				X			X				Temp. averaging input	(Unsupported)
–	X	X	X	X	X	X	X	X	X	X	Ground reference	⊥ (Common)
T2			X	X	X	X			X	X	Lower setpoint output with limits	AO1 or AO2*
R2			X	X	X	X			X	X	T2 override	(Unsupported)
T4			X		X	X			X		Lower setpoint output without limits	AO1 or AO2*

***AO1/AO2 connection is dependent on application and selected configuration. See [Connection and Configuration on page 5](#), the CTE-1xxx Thermostat Replaced chart above, and relevant application section.**

CTE-51xx Thermostat Replaced 							CTE-5202 Sequence Selected	Example Replacement Applications
KMC / Nailor / Dynacon*	Anemostat*	Carnes*	Metal Industries*	Nailor*	Price Industries*	ASC / Titus*		
CTE-5101		999-2662	01EC-2119	B3-3001-191 or B3-191	019814-001	10269601 / 10269606	#1	See page 34 , page 35 , and page 42
CTE-5102***	13-33					10269607	#3 (if T4 is not used)**	See page 34
CTE-5103	13-35	999-2663	01EC-2122	B3-3001-186 or B3-186	019810-001	10269608 / 10269603	#3 (if T3 and T4 are not used) **	See page 36 , page 38 , page 39 , page 40 , and page 43
CTE-5104	13-34	999-2664	01EC-2120	H1-981	019726-001 / 019816-001	10269604 / 10269609	#2	See page 36 , page 37 , and page 41
CTE-5105***					019822-001	10269610	#1 (if the setback feature is acceptable in place of two independent setpoints)	

*NOTE: CTE-510x thermostats require a power supply of 14–20 VDC, typically using the 16 VDC power supplied by a CSP-5001/5002 controller/actuator. The CTE-5202 can use the same 16 VDC power (or 14–35 VDC or 24 VAC). See also the [CSP-5001/5002 Application Guides](#).

**For applications requiring limited T1 and/or T2 signals and unlimited T3 and/or T4 signals, flow limits may need to be set on the controller (allowing the controller to use an unlimited signal). Limits for the CTE-5202 and AO1 and AO2 would then be left at the default 0 and 12.

***NOTE: Discontinued KMC models.

CTE-51xx/CTE-5202 Terminal Equivalents						
CTE-51xx Terminal	CTE-5101	CTE-5102	CTE-5103/5105	CTE-5104	Description	CTE-5202 Terminal
V1	X		X	X	Velocity input for read-out	(Unsupported)
T3	X		X	X	Upper setpoint output without limits	AO1 or AO2*
R1	X		X	X	T1 override, connect to “–” if unused	(Unsupported)
T1	X		X	X	Upper setpoint output with limits	AO1*
+	X	X	X	X	16 VDC power supply input	~ (Phase)
12V	X	X	X	X	12 VDC power output	(Unsupported)
A	X	X	X	X	Temp. averaging input	(Unsupported)
–	X	X	X	X	Ground reference	⊥ (Common)
T2**		X	X	X	Lower setpoint output with limits**	AO1 or AO2*
R2**		X	X	X	T2 override (voltage applied to R2 subtracts from T2), connect to “–” if unused**	(Unsupported)
T4		X	X		Lower setpoint output without limits	AO1 or AO2*
V2		X	X		Velocity input for read-out	(Unsupported)

*AO1/AO2 connection is dependent on application and selected configuration. See [Connection and Configuration on page 5](#), the CTE-51xx Thermostat Replaced chart above, and relevant application section.

Except CTE-5104, in which T2 lower setpoint output is **without limits. Also CTE-5104’s R2 is auxiliary limit trigger, in which voltage above 1 VDC to R2 indexes T1 to the auxiliary flow limit.

Display Is Blank

- If the display comes on for no more than 30 seconds after a button is pushed and then blanks out, Display Blanking is enabled in the *SYSTEM* menu. See [Change Configuration on page 6](#).
- Check for a tripped circuit breaker to the transformer.
- Check for proper supply voltage from the transformer and that the transformer has enough capacity (VA) for all connected devices See their respective data sheets and [Tips for Connecting 24-Volt Power Application Note \(AN0604D\)](#).

Setpoint Is Not Maintained

- Check that room temperature is being sensed correctly. See [Temperature Reading Is Incorrect on page 11](#).
- Check that the appropriate sequence is selected in the *SYSTEM* menu. See [Change Configuration on page 6](#) and the relevant sample application.
- If changeover is used on AI1, check the sensor and the changeover setting in the *ADVANCE* menu. If a resistor is used on AI1 to force a changeover without a temperature sensor, the value of the resistor may be too high or too low. See [External Input \(AI1\) on page 5](#), [Change Configuration on page 6](#), and the relevant sample application.
- If a setback switch/relay is used on AI1, the switch may be (stuck) in the setback position. See [page 37](#).
- If an override switch/relay is used on AO1, the switch may be (stuck) in the override position. See [page 19](#), [page 35](#), and [page 47](#).
- Check settings of auxiliary flow and other limits as relevant in the *LIMITS* menu. See [Change Configuration on page 6](#).
- If the HVAC system has trouble recovering from the unoccupied setback to the occupied setpoint during very cold weather, adjust the setback in the *ADVANCE* menu. See [Change Configuration on page 6](#).

- If space temperature is overshooting the setpoint or oscillating, try increasing the proportional band by a degree in the *ADVANCE* menu. If the problem persists, try increasing the integral value slightly (up to 20%). If the problem still persists, try setting the integral value to 0. (The optimal integral value is dependent on the characteristics of the particular space and HVAC system.) See [Change Configuration on page 6](#).

Temperature Reading Is Incorrect

- Check that the correct °F/C temperature scale is selected in the *SYSTEM* menu. See [Change Configuration on page 6](#).
- If the discrepancy is small, adjust the room temperature offset in the *ADVANCE* menu. See [Change Configuration on page 6](#).
- Check that the thermostat is **NOT** mounted on an exterior wall, mounted on or near a large thermal mass (e.g., concrete block wall), blocked from normal air circulation by obstructions, exposed to heat sources (e.g., lights, computers, copiers, coffee makers) or to sunlight (at **any** time of the day), exposed to drafts from windows or air vents, or exposed to air flow through the conduit from leaks in plenum ducts (put plumber's putty or other sealant inside conduit to block air leaks).

Wiring Issues

- Check for correct wiring for the application. See [Connections on page 5](#) and the various application examples in this document.
- Remove the thermostat from the backplate and inspect the terminals for loose wires. See the installation guide for the **CTE-5202**.
- Check the wiring at the connected devices.
- Use a voltmeter and ohmmeter to check the terminals for expected values.

NOTE: Wiring must be adequate to avoid excessive voltage drop on long runs! Allow plenty of "cushion" in measurements A meter may be too slow to register transient dips or peaks during startup.

Single-Zone Proportional Heating and Cooling Applications

This section gives sample applications for using the CTE-5202 in single zone proportional heating (baseboard heaters) and cooling (chilled beams) with valves or SCR control.

NOTE: For chilled beam applications, separate control of humidity is required to prevent condensation.

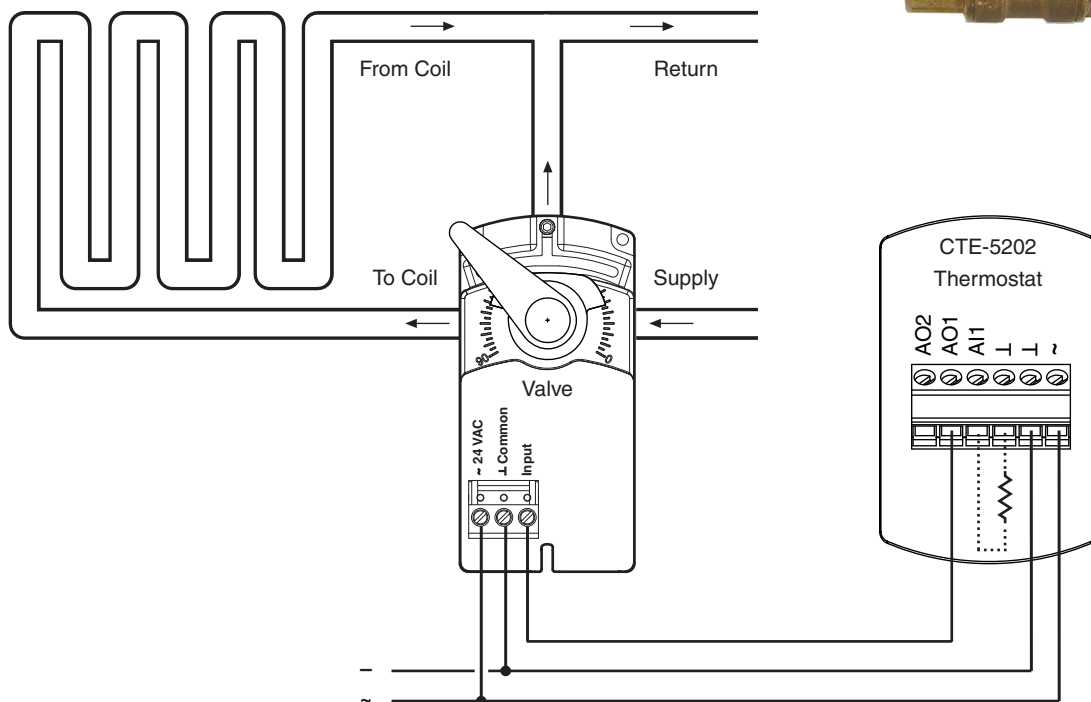
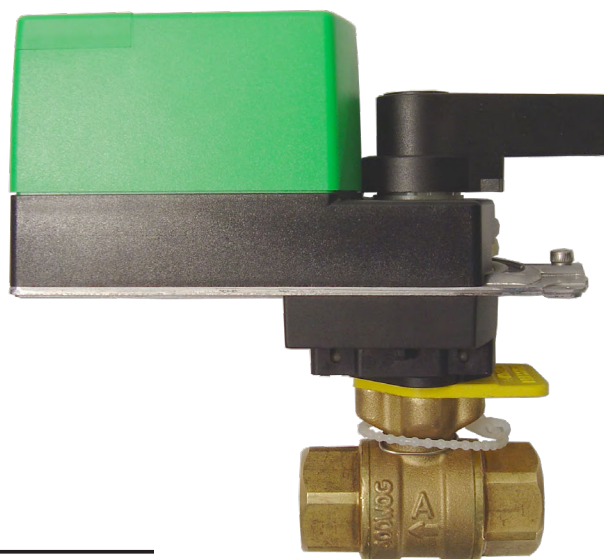

Heating, RA and DA

CTE-5202 thermostats can use a variety of valves for heating/cooling applications with hot and chilled water. For **Reverse Acting control**, connect a 5K to 10K ohm resistor between Common and AI1. Select Sequence 1 (from the CTE-5202 *SYSTEM* menu) and lower the Changeover (in the *ADVANCE* menu) to the lowest setting (55° F). See [Change Configuration on page 6](#). The resistor simulates a changeover sensor and puts the thermostat in Reverse Acting mode.

NOTE: If the resistor value is too high, the thermostat will not go into RA mode. If the resistor value is too low, the thermostat may go into setback mode.

This RA control works for NO 2–10 and 0–10 VDC valves or NC 10–2 and 10–0 VDC valves as well as equivalent SCR controls.

For **Direct Acting control**, select Sequence 1 (from the CTE-5202 *SYSTEM* menu). See [Change Configuration on page 6](#). (Do not connect the resistor.)

This DA control works for NC 2–10 and 0–10 VDC valves or NO 10–2 and 10–0 VDC valves as well as equivalent SCR controls.

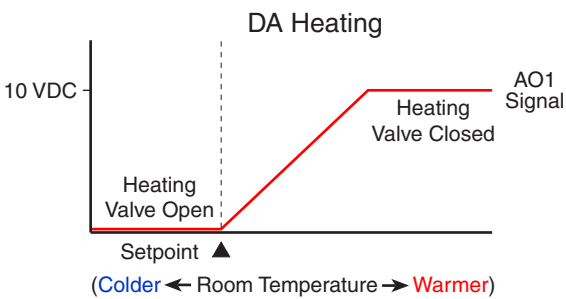
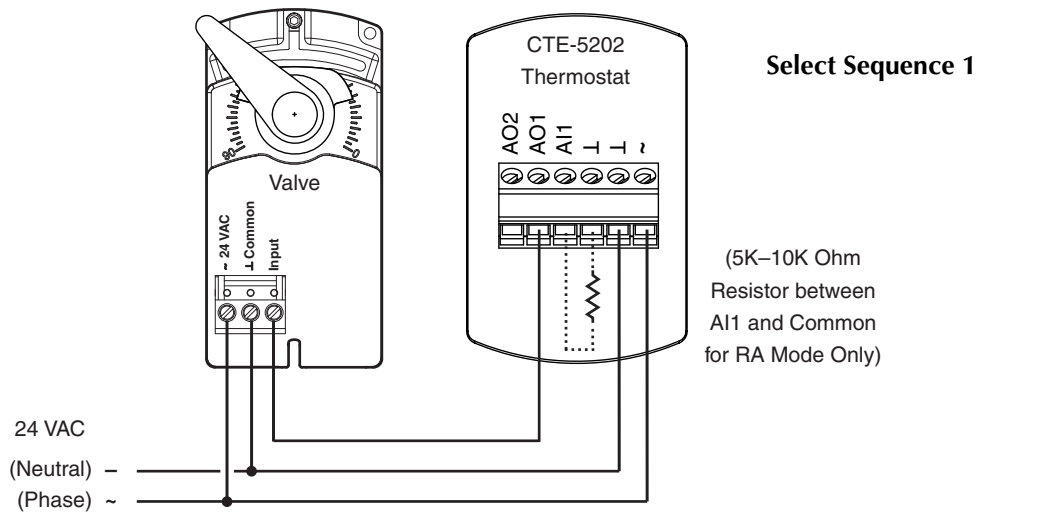

Select Sequence 1

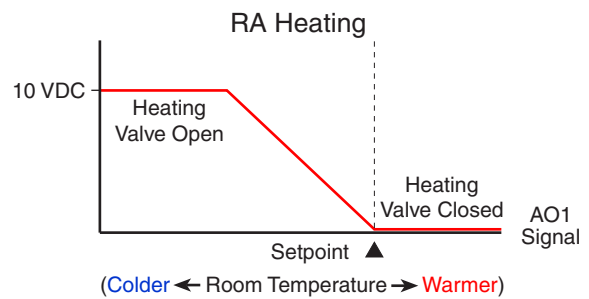

Select Sequence 1
AND Set Changeover to 55° F

Chilled Beam Cooling

This application controls cooling in a chilled beam or equivalent installation.

This works for NC 2–10 and 0–10 VDC valves or NO 10–2 and 10–0 VDC valves.

Select Sequence 1 (from the CTE-5202 *SYSTEM* menu). See [Change Configuration on page 6](#).

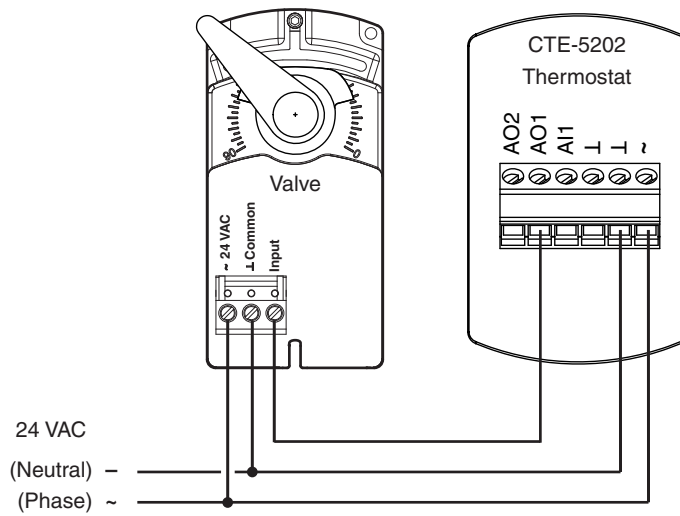

Select Sequence 1

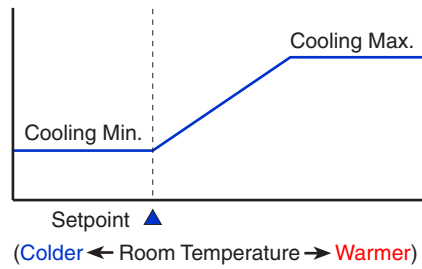

Chilled Beam 4-Pipe Heating and Cooling

This application enables both heating and cooling in a chilled beam and baseboard or equivalent installation.

Select Sequence 3 from the CTE-5202 *SYSTEM* menu. See [Change Configuration on page 6](#).

This works for NC 2–10 and 0–10 VDC valves or NO 10–2 and 10–0 VDC valves.

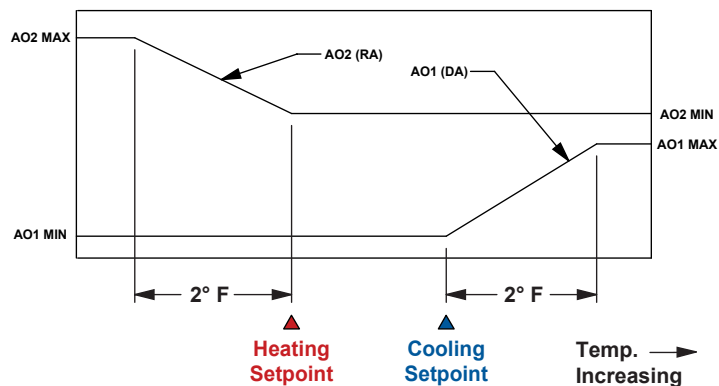
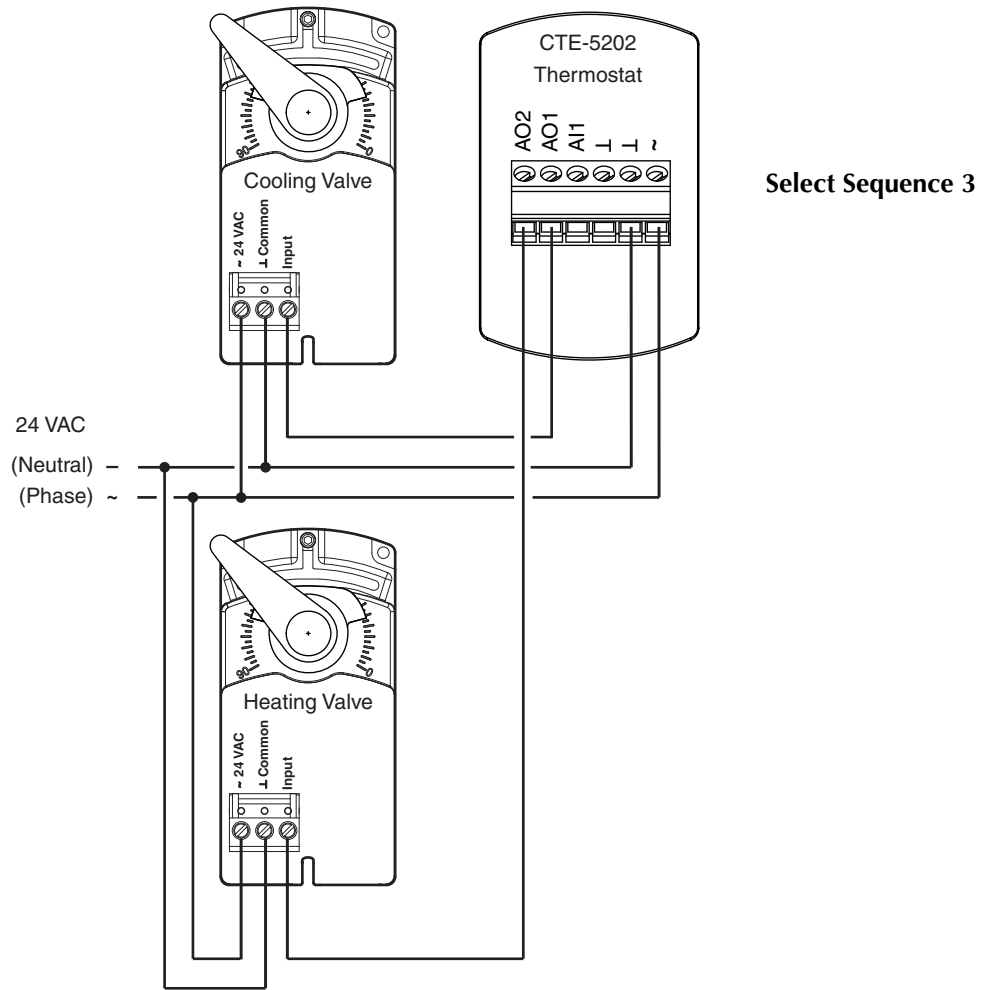

Chilled Beam 2-Pipe Heating and Cooling with Changeover

An STE-1454/1455 strap-on (Type III) temperature sensor provides the CTE-5202 an automatic change-over for heating/cooling applications using hot and chilled water. The sensor will switch the thermostat between cooling and heating modes based on the temperature of the water in the pipe. A water temperature higher than changeover temperature, switches control to heating mode, and a temperature lower than changeover temperature, switches control to cooling mode.

Select Sequence 1 from the CTE-5202 *SYSTEM* menu. Change the default changeover temperature to the maximum of 85° in the CTE-5202 *ADVANCE* menu. See [Change Configuration on page 6](#) and [Hot/Cold Changeover on page 5](#).

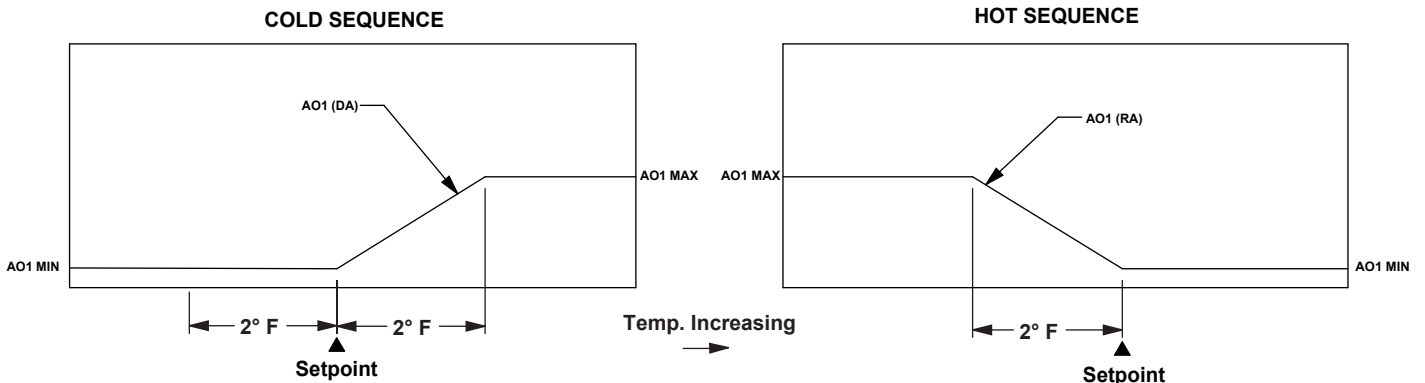
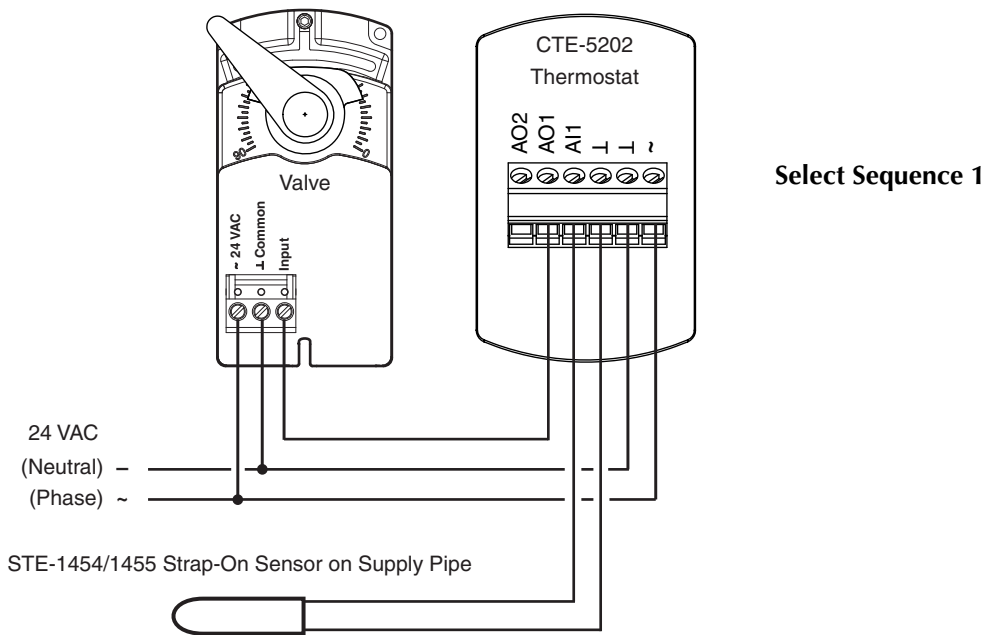

Pressure Dependent VAV Applications with MEP-4xx2

This section gives sample applications for using the CTE-5202 with the MEP-4xx2 actuator in pressure dependent VAV applications.

The MEP-4xx2's default direction is CCW to close (CW to open or CW with increasing voltage), but this can be reversed by a switch during installation and configuration.

See also the [MEP-4000 Series](#) Installation Guide.

For additional applications, see [Pressure Independent VAV Applications with CSP-5001/5002 on page 33](#) and make the corresponding wiring adjustments for power to the MEP-4xx2 and CTE-5202.

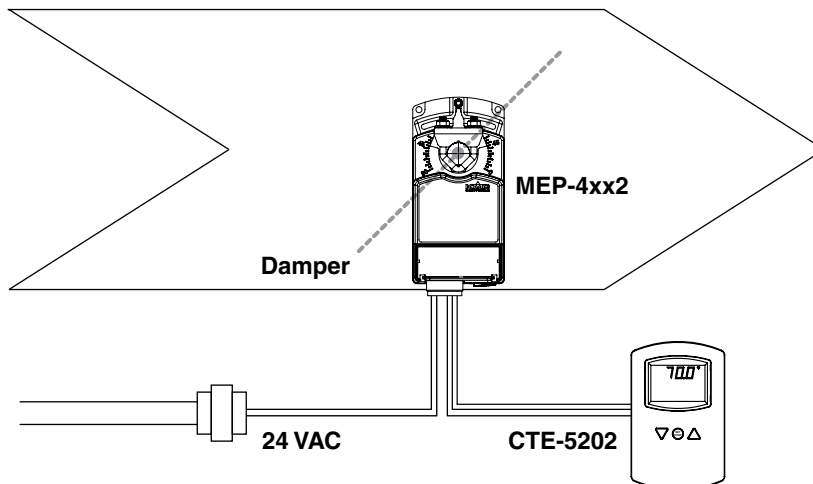

Cooling or Heating

CTE-5202 thermostats can use MEP-4xx2 actuators to operate damper boxes in a pressure-dependent VAV system. As shown in the diagram, a “requested flow” voltage signal (AO1) is connected to the MEP-4002 to adjust airflow from minimum to maximum flow according to space demand. Minimum and maximum flow limit adjustments can be made at the thermostat (recommended) or at the actuator. (See the [MEP-4000 Series Installation Guide](#).)

For **cooling**, select Sequence 1 (from the CTE-5202 SYSTEM menu). See [Change Configuration on page 6](#).

For **heating**, connect a 5K to 10K ohm resistor between Common and AI1. Select Sequence 1 and lower the Changeover to the lowest setting (55° F). See [Change Configuration on page 6](#). The resistor simulates a changeover sensor and puts the thermostat in Reverse Acting mode.

NOTE: If the resistor value is too high, the thermostat will not go into RA mode. If the resistor value is too low, the thermostat may go into setback mode.

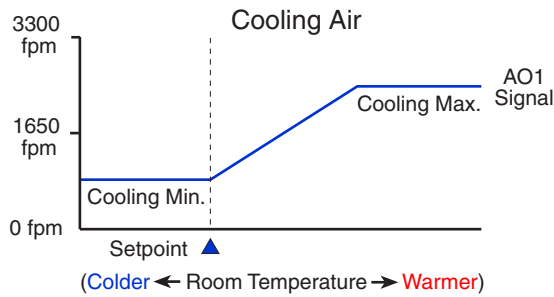
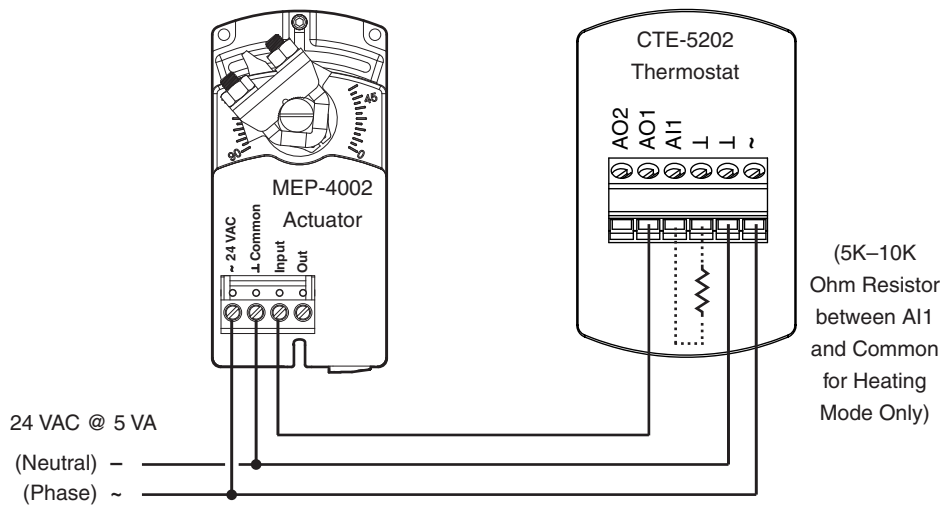

Select Sequence 1

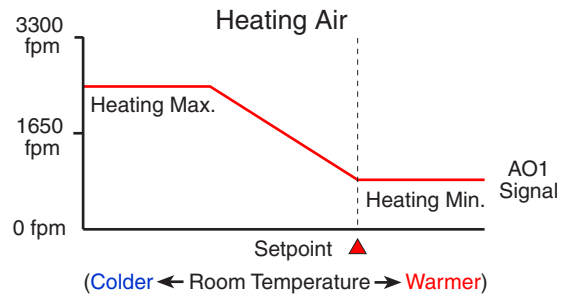

Select Sequence 1
AND set Changeover to 55° F

Auto and Override (to Fully Closed)

Adding a Normally Closed SPST relay or switch enables overriding the air flow to fully closed. (Otherwise the example below is the same as the configuration in *Cooling or Heating on page 18*).

The default setting is Auto. When the NC relay energizes, the thermostat signal is removed from the actuator's input. The resulting 0 VDC "signal" on the actuator's input overrides the actuator to fully closed.

NOTE: An override to fully open does not apply to the MEP-4xx2 in a way that is analogous to the CSP-5001 as shown in *Auto and Override (to Fully Closed or Fully Open) on page 35*.

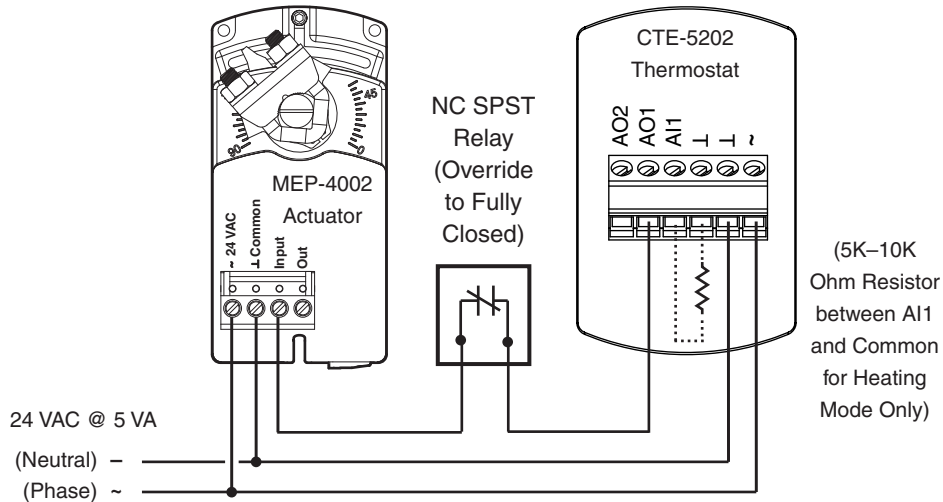

Other Applications

See the corresponding application in *Pressure Independent VAV Applications with CSP-5001/5002 on page 33* and make the corresponding wiring adjustments for power to the MEP-4xx2 and CTE-5202.

The MEP-4xx2's default direction is the same as the CSP-5001.

Replacing a CSP-5001/5002

The CSP-4702 can be used in any of the CSP-5001/5002 applications shown in the section [Pressure Independent VAV Applications with CSP-5001/5002 on page 33](#). However, there are some differences among the models of which the installer must be aware:

- Output torque of the CSP-4702 is 40 in. lb. instead of the CSP-500x's 50 in. lb. Check torque requirements of the damper when replacing a CSP-500x.
- Factory-set rotation direction of the CSP-4702 is CCW to close and CW to open, the same as the CSP-5001. The direction can be reversed by changing the position of a jumper.
- If a CSP-4702 is used to replace an existing CSP-500x and **limits were set in the CSP-500x**, the limits will need to be set (in either the CSP-

4702 or the thermostat). If a CSP-4702 is used to replace an existing CSP-500x and **limits were set in the thermostat**, the limits in the thermostat should be checked and adjusted to ensure accuracy.

- The terminals on the CSP-4702 terminal strips are in a different order than on a CSP-500x.
- “Override to Fully Closed” shown in [Auto and Override \(to Fully Closed or Fully Open\) on page 35](#) will not work as described with the CSP-4702. See the Operation Test section of the [CSP-4702 Installation Guide](#).

NOTE: Compare the wiring of the CSP-4702 version of cooling with heating changeover below to the CSP-5001 version in [Cooling with Heating Changeover on page 38](#). See also [Cooling with Heating Changeover on page 27](#).

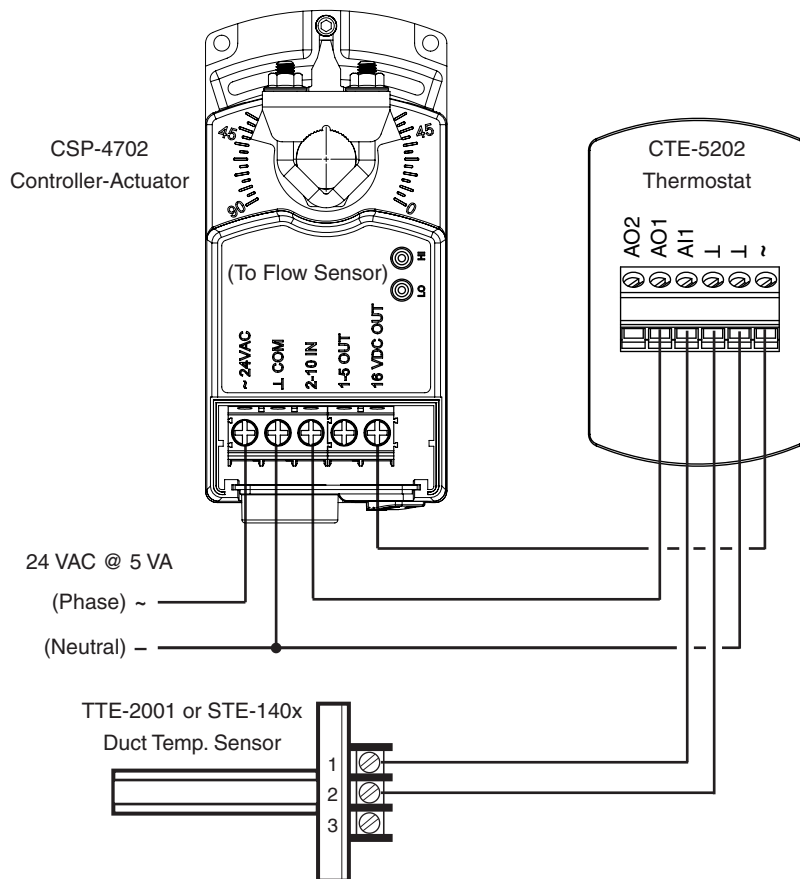

Replacing a CEP-4xxx or CSP-40xx/42xx/44xx/46xx or CSE-484x

With changes to the sensors, the CSP-4702 can generally be used in any of the older CEP-4xxx and CSP-40xx/42xx/44xx/46xx applications shown in the section *Pressure Independent VAV and CAV Applications with CEP/CSP-4000 Series on page 44*.

Although it may sound as if it belongs in the same series, the new CSP-4702 is quite different from the discontinued CSP-40xx/42xx/44xx/46xx models.

There are some differences among the models of which the installer must be aware:

- CEP-4xxx and CSP-40xx/42xx/44xx/46xx controllers supply 9.1 VDC for connected thermostats. The CSP-4702 (like the CSP-500x controllers) outputs 16 VDC. When replacing an older controller, any connected thermostat that operates from 9.1 VDC power must also be:
 - Replaced with the **CTE-5202** that operates from the 16 VDC supplied by the CSP-4702.
 - Or powered by an **XEE-4002** power supply (connected to the transformer) to deliver 9.1 VDC to the existing thermostat.
- If replacing a CEP-4xxx, an attached SSE-xxxx sensor must be replaced with an **SSS-100x** sensor. For an existing SSE-200x used for duct temperature sensing, terminals X and Y can continue to be used for duct temperature sensing, and an SSS-100x air flow sensor can be installed separately.
- If a CSP-4702 is used to replace an existing CxP-4xxx and **limits were set in the CxP-4xxx**, the limits will need to be set (in either the CSP-4702 or the thermostat). If a CSP-4702 is used to replace an existing CxP-4xxx and **limits were set in the thermostat**, the limits in the thermostat should be checked and adjusted to ensure accuracy.

- The terminals on a CxP-4xxx are very different than on a CSP-4702:
 - 10 = 24 VAC phase
 - 9 = 24 VAC neutral/common
 - 6 = Input from thermostat
 - 5 = Power (VDC) to thermostat
 - 4 = Common
 - 3, 2, and 1 = to SSE-1xxx flow sensor, no longer used (but SSE-2xxx sensors can still be used for duct temperature sensing)

NOTE: Compare the wiring of the CSP-4702 version of cooling with heating changeover below to the CEP-4xxx version in *Cooling with Heating Changeover on page 49*. See also *Cooling with Heating Changeover on page 27*.

NOTE: The discontinued CSE-484x is similar to a CSP-4xxx, but it does not have a built-in actuator. A CSP-4702 can replace a CSE-484x together with its external actuator.

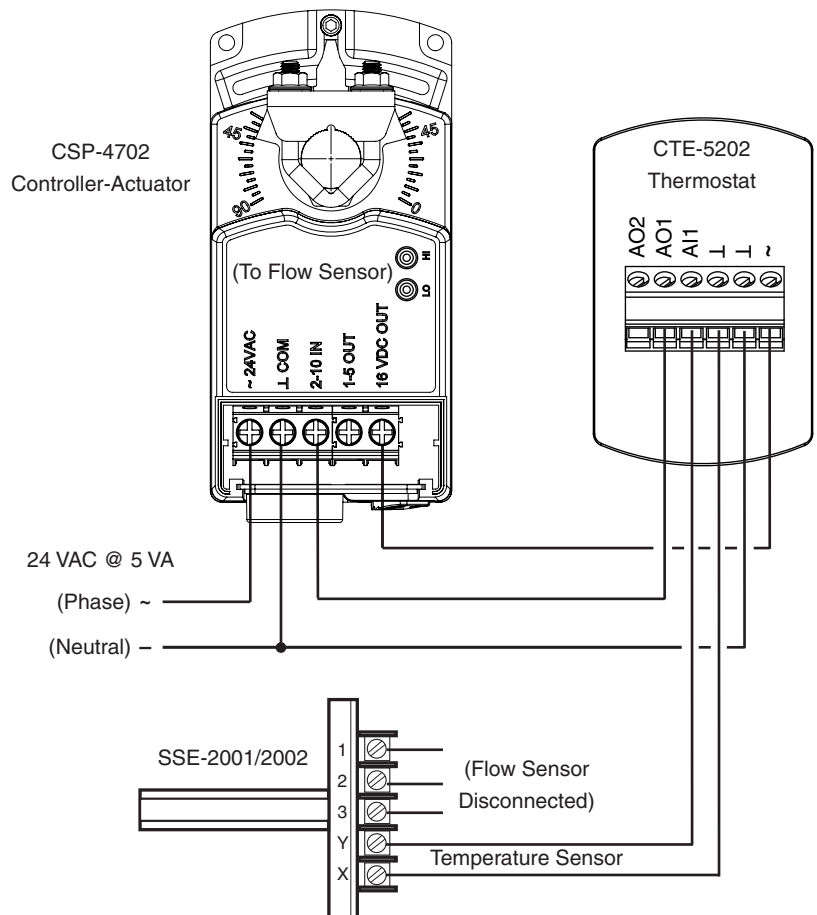

Cooling or Heating

CTE-5202 thermostats can use CSP-4702 electronic VAV controllers to operate damper boxes in the pressure-independent VAV system. As shown in the diagram, a “requested flow” voltage signal (AO1) is connected to the CSP-4702 to adjust airflow from minimum to maximum flow according to space demand. Minimum and maximum flow limit adjustments can be made at the thermostat or at the controller.

For **cooling**, select Sequence 1 (from the CTE-5202 SYSTEM menu). See [Change Configuration on page 6](#).

For **heating**, connect a 5K to 10K ohm resistor between Common and AI1. Select Sequence 1 and lower the Changeover to the lowest setting (55° F). See [Change Configuration on page 6](#). The resistor simulates a changeover sensor and puts the thermostat in Reverse Acting mode.

NOTE: If the resistor value is too high, the thermostat will not go into RA mode. If the resistor value is too low, the thermostat may go into setback mode.

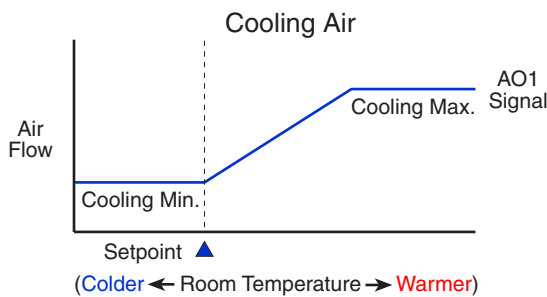
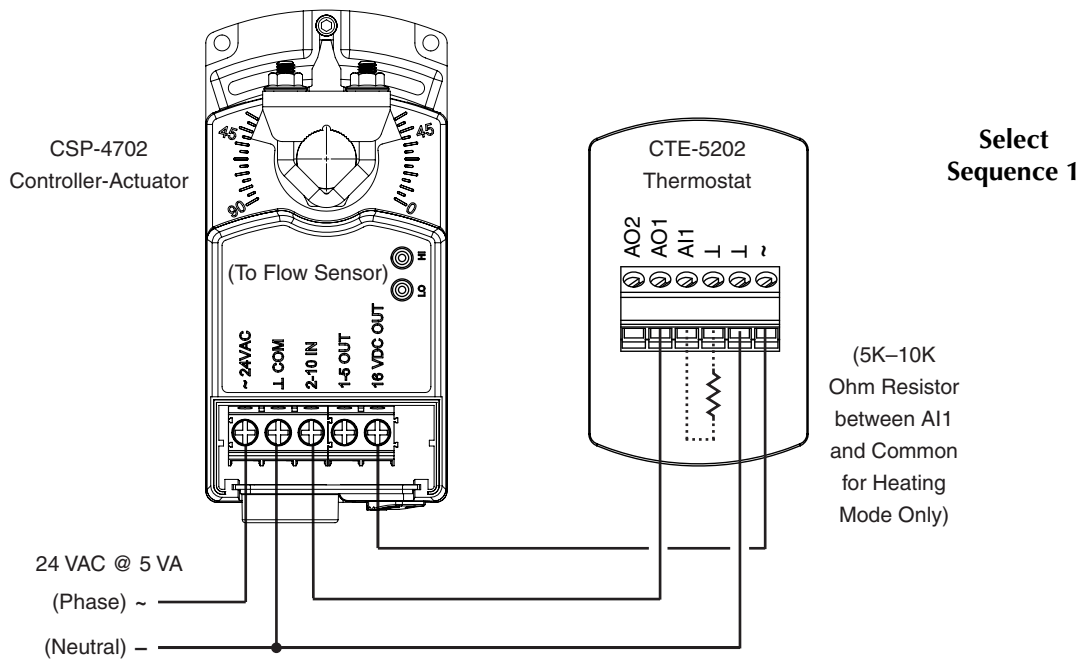

Select Sequence 1

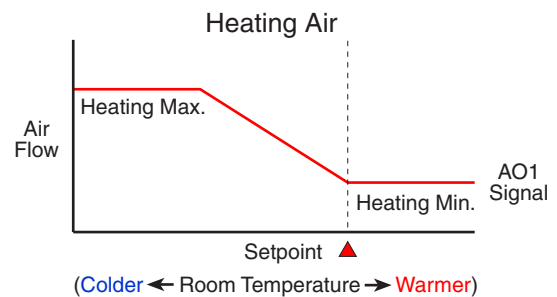

Select Sequence 1
AND Set Changeover to 55° F

Auto and Override (to Fully Open)

Adding a SPDT relay or switch enables overriding the air flow to fully open. (Otherwise the example below is the same as the **cooling** configuration in [Cooling or Heating on page 23.](#))

The SPDT relay selects one of the two modes (Auto/Open). In the relay position shown below (Open), the controller will override the flow setting. (Jumping “2-10 IN” and “16 VDC OUT” drives the CSP-4702 fully open.)

NOTE: If a maximum limit was set in the CSP-4702 controller, the damper will only open to the maximum limit setting. See also the Operation Test section of the [CSP-4702 Installation Guide.](#)

When the relay switches to Auto, the thermostat will then control the VAV box based on demand.

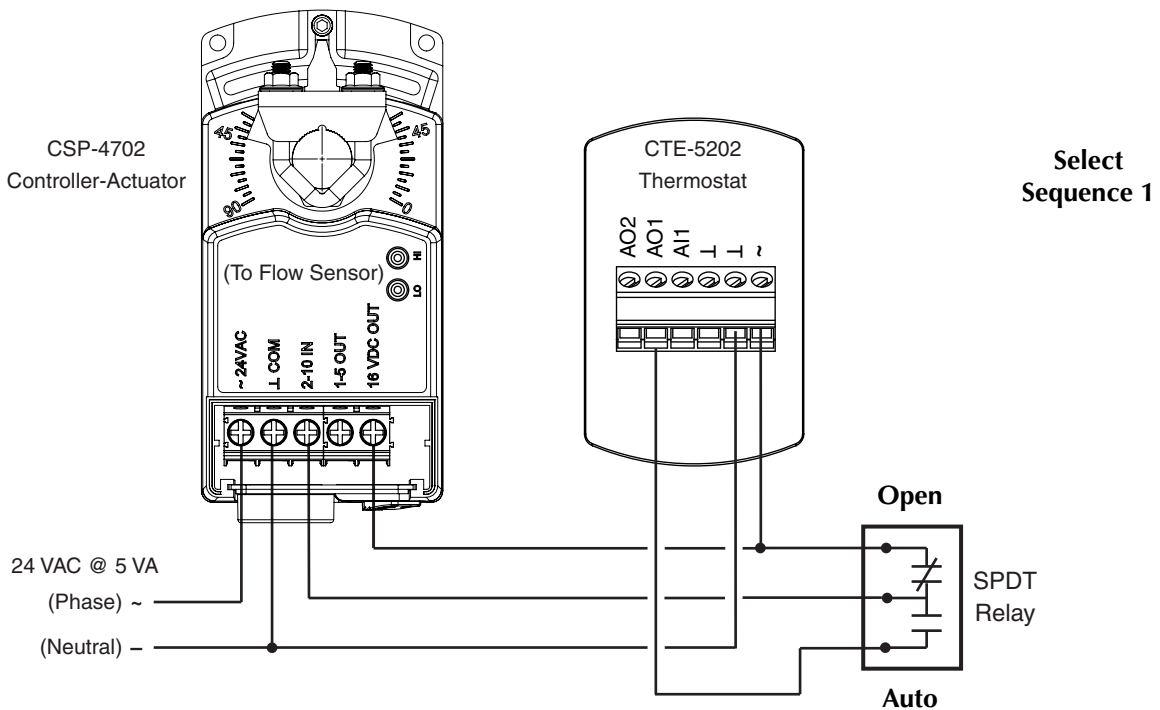

Cooling with 3-Stage Reheat

This application uses a CSP-4702 along with an REE-5001 relay module and three 24 VAC contactors for three stages of reheat.

As the temperature drops below setpoint, the first stage of reheat begins. As the temperature continues to drop, the second stage and later the third stage begin as needed.

Select Sequence 2 (from the CTE-5202 *SYSTEM* menu), with or without Auxiliary Flow (*AO1 AUX* in *LIMITS* menu). See [Change Configuration on page 6](#).

NOTE: Triac outputs on the REE-5001 are for 24 VAC loads only. The phase side of the transformer connects to the “common” side of the load (contactors).

NOTE: See also the [REE-5001 Installation Guide](#).

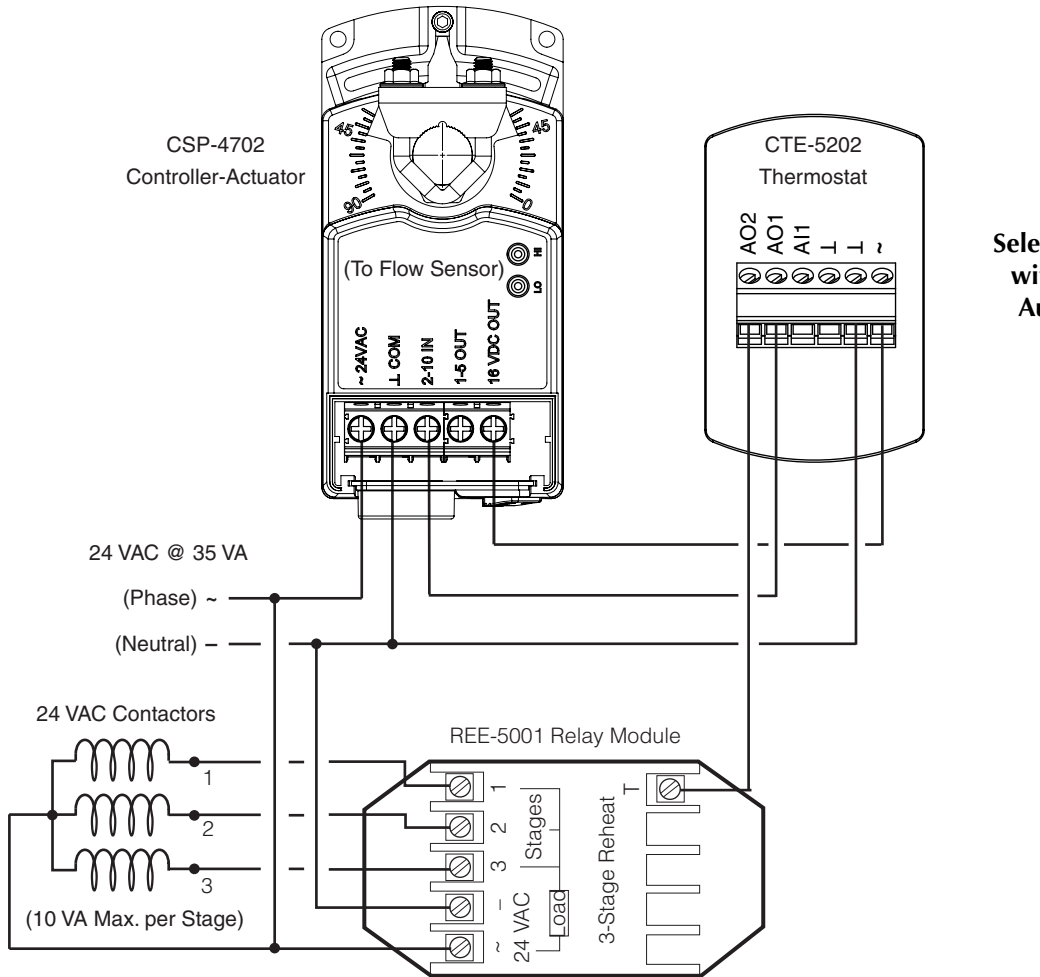

Select Sequence 2,
with or without
Auxiliary Flow

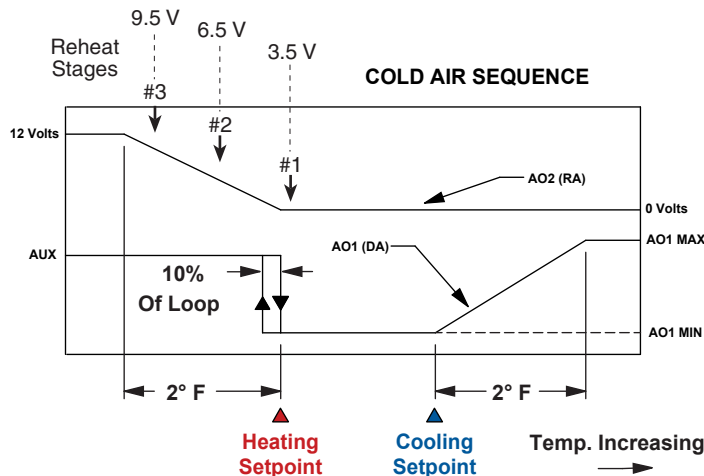

Cooling with 3-Stage Reheat and Night Setback/Setup

This configuration is the same as on the previous page except for the addition of an SPST relay or switch. See [Cooling with 3-Stage Reheat on page 25](#).

The switch or relay is driven by a night/unoccupied setback/setup signal from other equipment not shown. When the contact is closed (e.g., by a timer), setback/setup mode initiates, changing the setpoint by the offset selected in *ADVANCE > SETBACK* menu. See [Change Configuration on page 6](#) and [Unoccupied/Standby Setback on page 5](#).

NOTE: The night/unoccupied setback offset does not apply to morning warm-up.

NOTE: This configuration requires the system fan to be on during setback/setup mode.

NOTE: Triac outputs on the REE-5001 are for 24 VAC loads only. The phase side of the transformer connects to the “common” side of the load (contactors).

NOTE: See also the [REE-5001](#) Installation Guide.

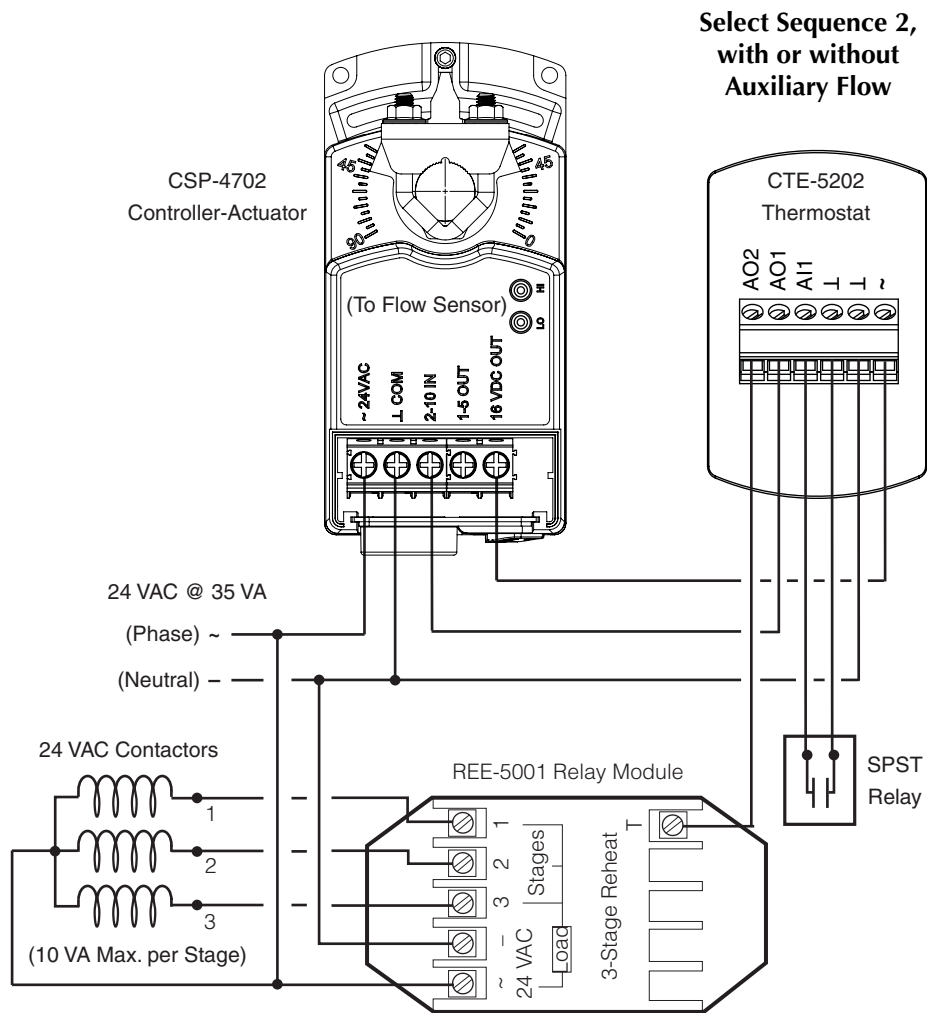

Cooling with Heating Changeover

Using a duct sensor with the CTE-5202, an automatic changeover is provided for cooling/heating applications. The duct sensor will switch the thermostat between cooling and heating modes based on the temperature of the duct supply air. A duct temperature higher than changeover temperature switches control to heating mode, and a temperature lower than changeover temperature switches control to cooling mode.

Select Sequence 1 (from the CTE-5202 *SYSTEM* menu). See *Change Configuration on page 6* and *Hot/Cold Changeover on page 5*. The default changeover temperature is 77° F, configurable from 55 to 85° F in the CTE-5202 *ADVANCE* menu.

NOTE: Minimums can be set at zero air flow, but a minimum of greater than zero is required for a quick changeover.

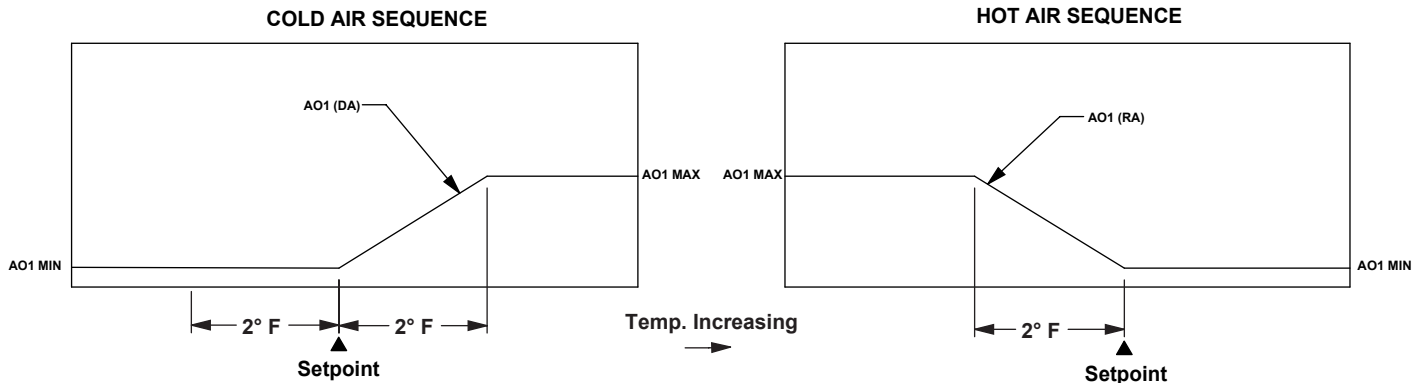
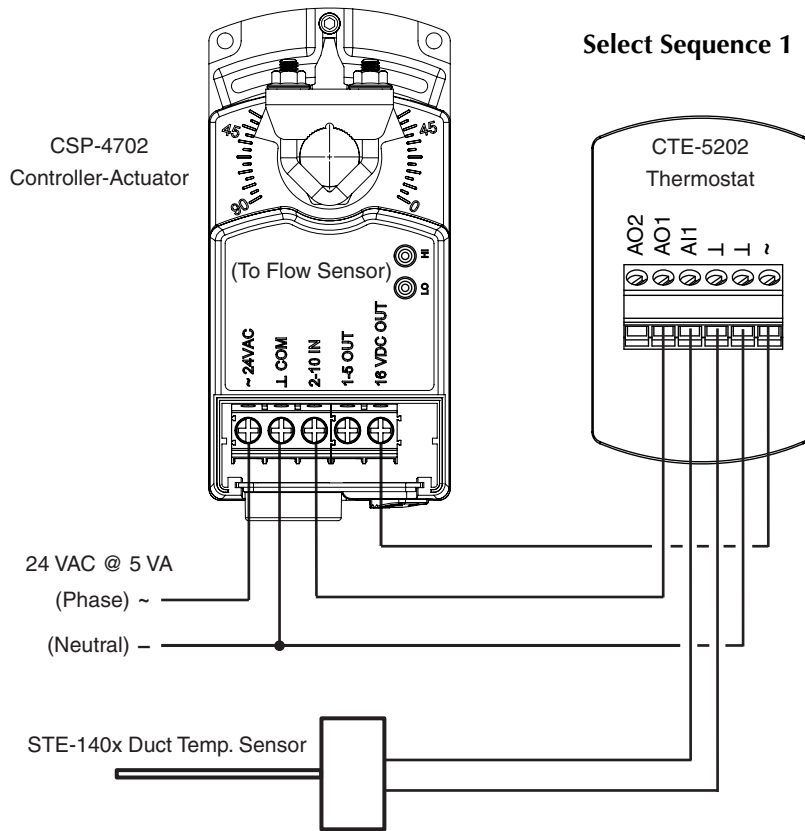

Cooling with Heating Changeover and Electric Reheat

This configuration is the same as the previous page except for the addition of an REE-5001 relay module connected to AO2 (for three stages of reheat) and selecting Sequence 2 from the CTE-5202 SYSTEM menu. See [Change Configuration on page 6](#), [Hot/Cold Changeover on page 5](#) and [Cooling with Heating Changeover on page 27](#). See also [Cooling with 3-Stage Reheat on page 25](#).

NOTE: Minimums can be set at zero air flow, but a minimum of greater than zero is required for a quick changeover.

NOTE: Triac outputs on the REE-5001 are for 24 VAC loads only. The phase side of the transformer connects to the “common” side of the load (contactors).

NOTE: See also the [REE-5001](#) Installation Guide.

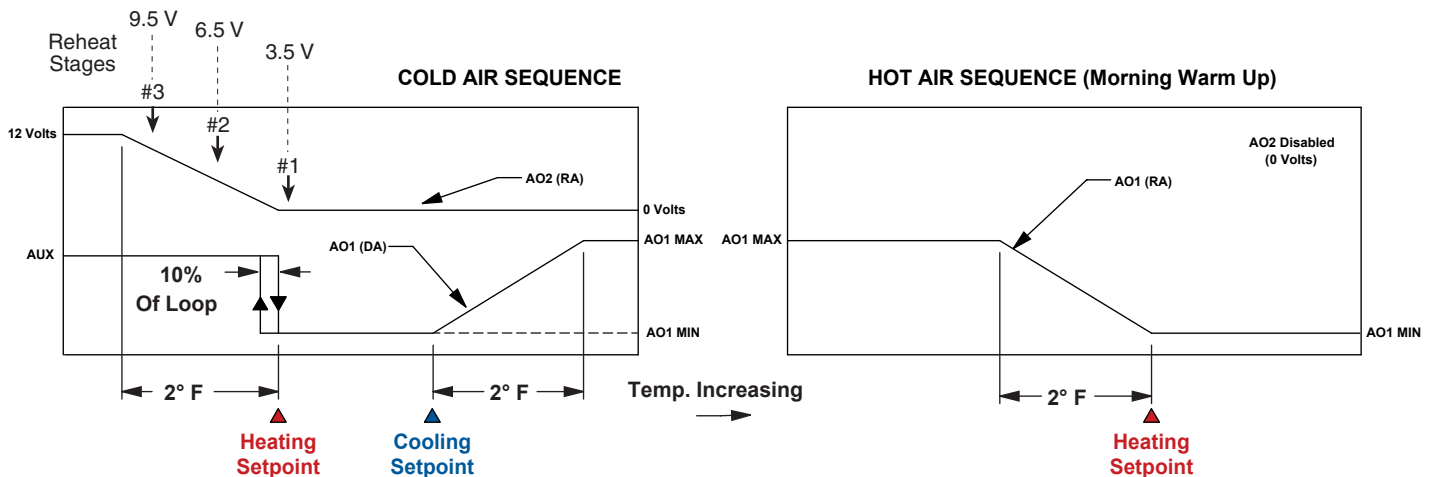
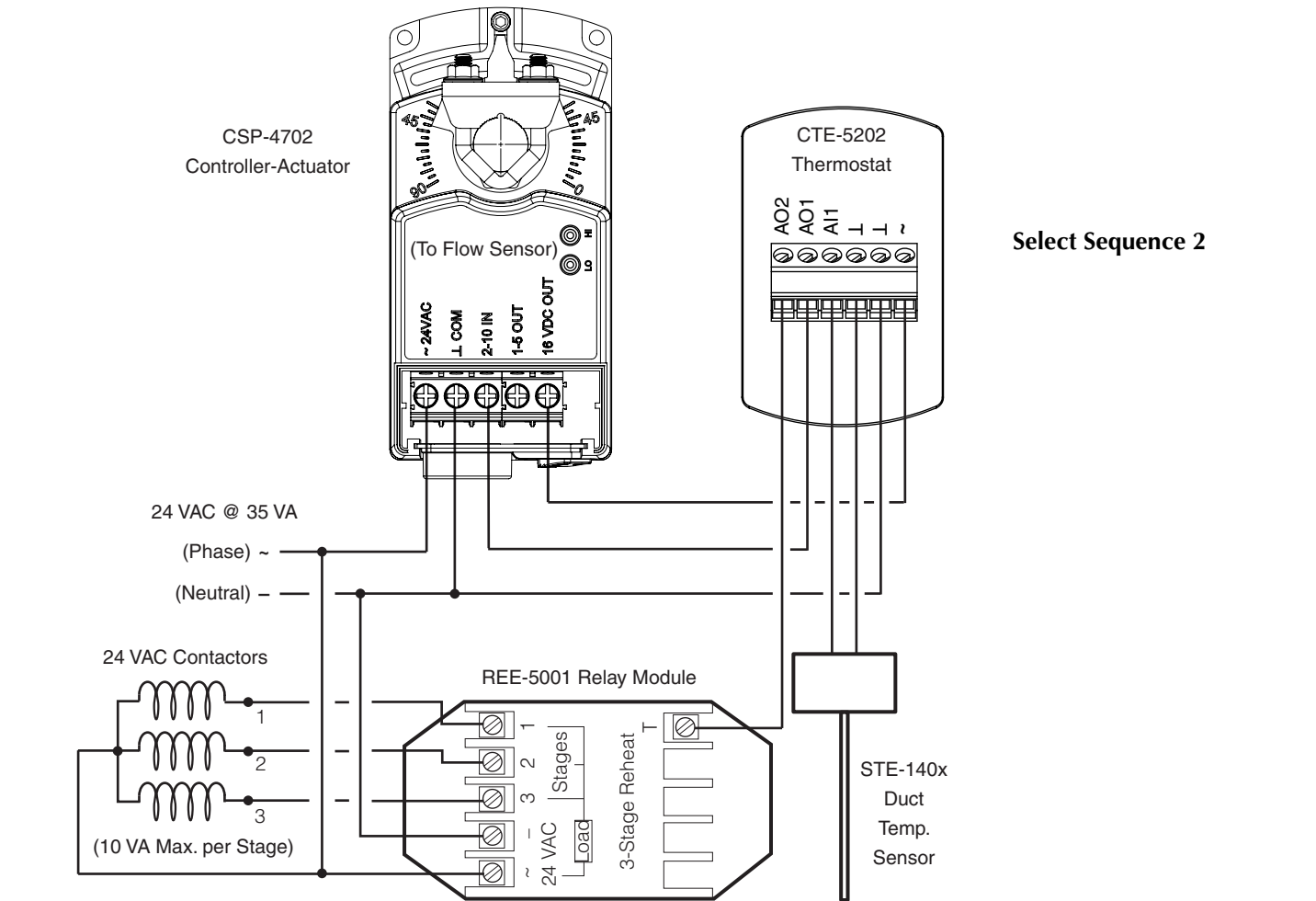

Cooling with Heating Changeover and Hot Water Reheat

See [Cooling with Heating Changeover and Electric Reheat on page 28](#). This application operates the same except for using a hot water valve instead of electric heating elements for reheat (a VEB-43/46 series valve in place of the REE-5001 relay).

When there is hot air in the duct, changeover initiates, allowing the heating signal from AO1 to control airflow and AO2 to control the valve. When there is a call for heat, the thermostat modulates the hot water valve.

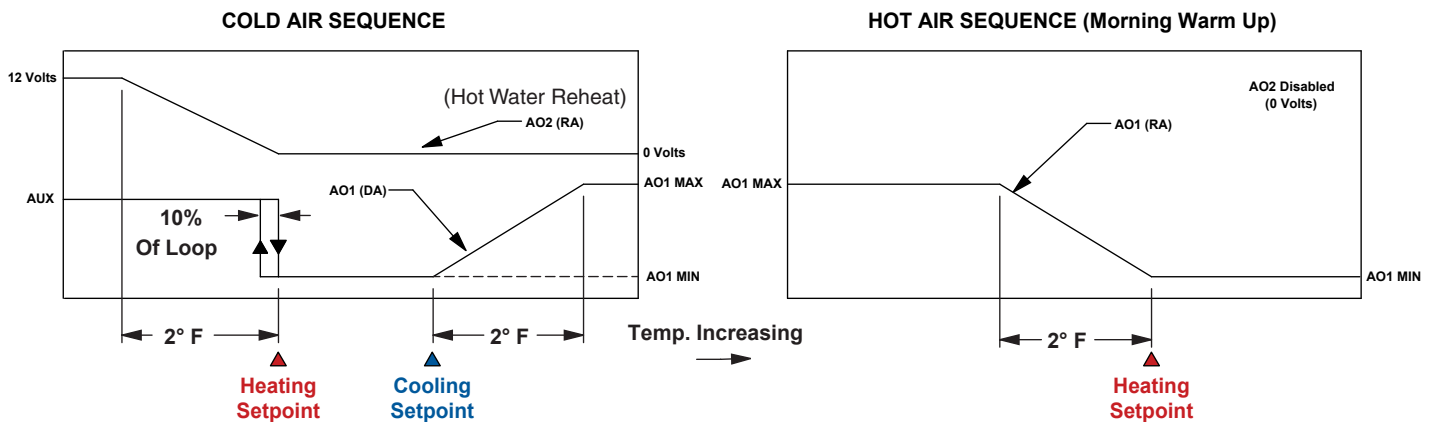
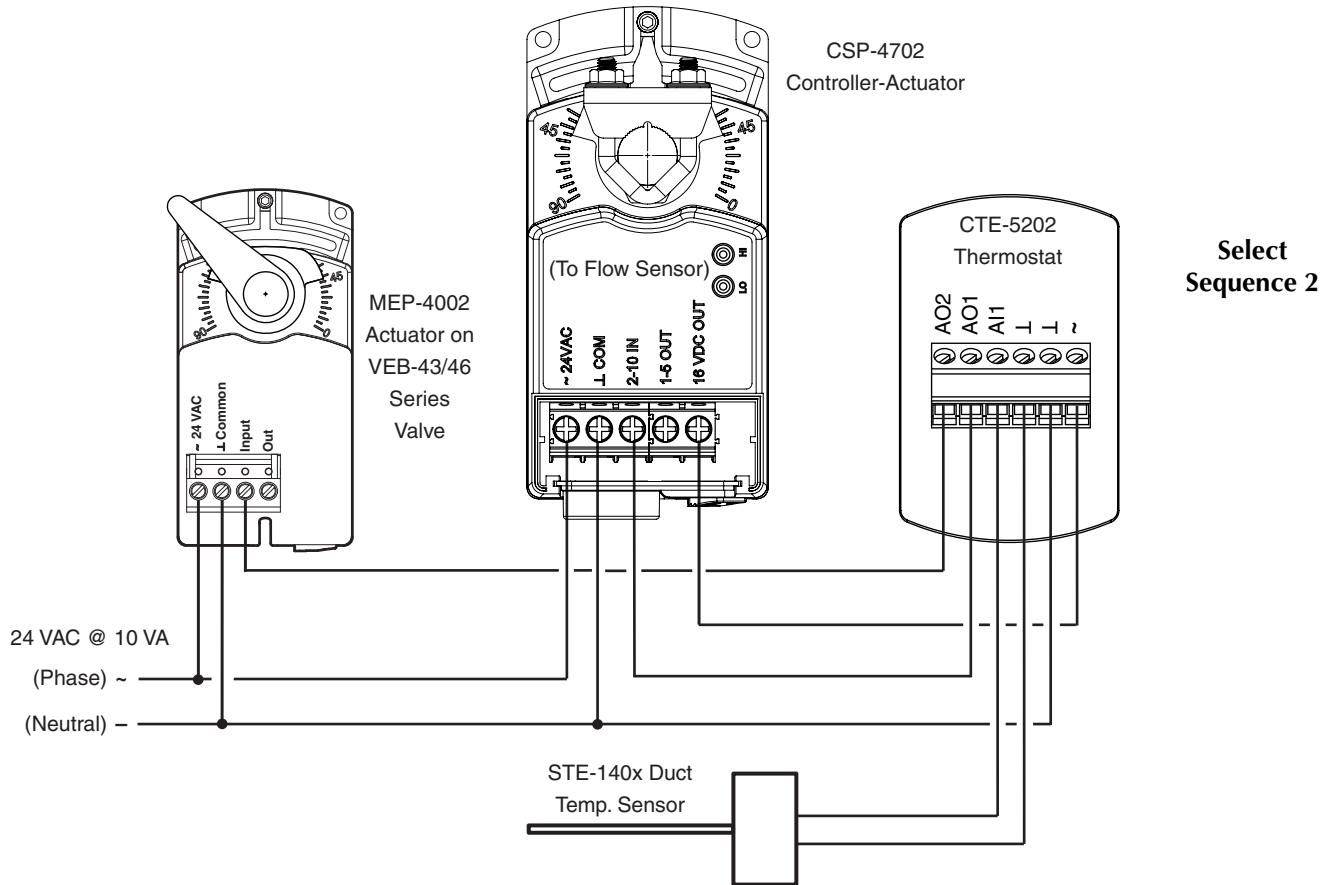

Cooling with Hot Water Reheat

See [Cooling with 3-Stage Reheat on page 25](#). This application operates the same except for using a hot water valve instead of electric heating elements for reheat (a VEB-43/46 series valve in place of the REE-5001 relay).

AO1 controls airflow and AO2 controls the valve. When there is a call for heat, the thermostat modulates the hot water valve.

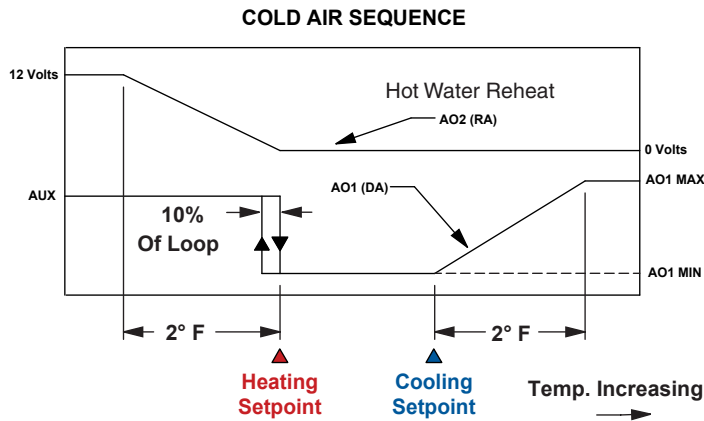
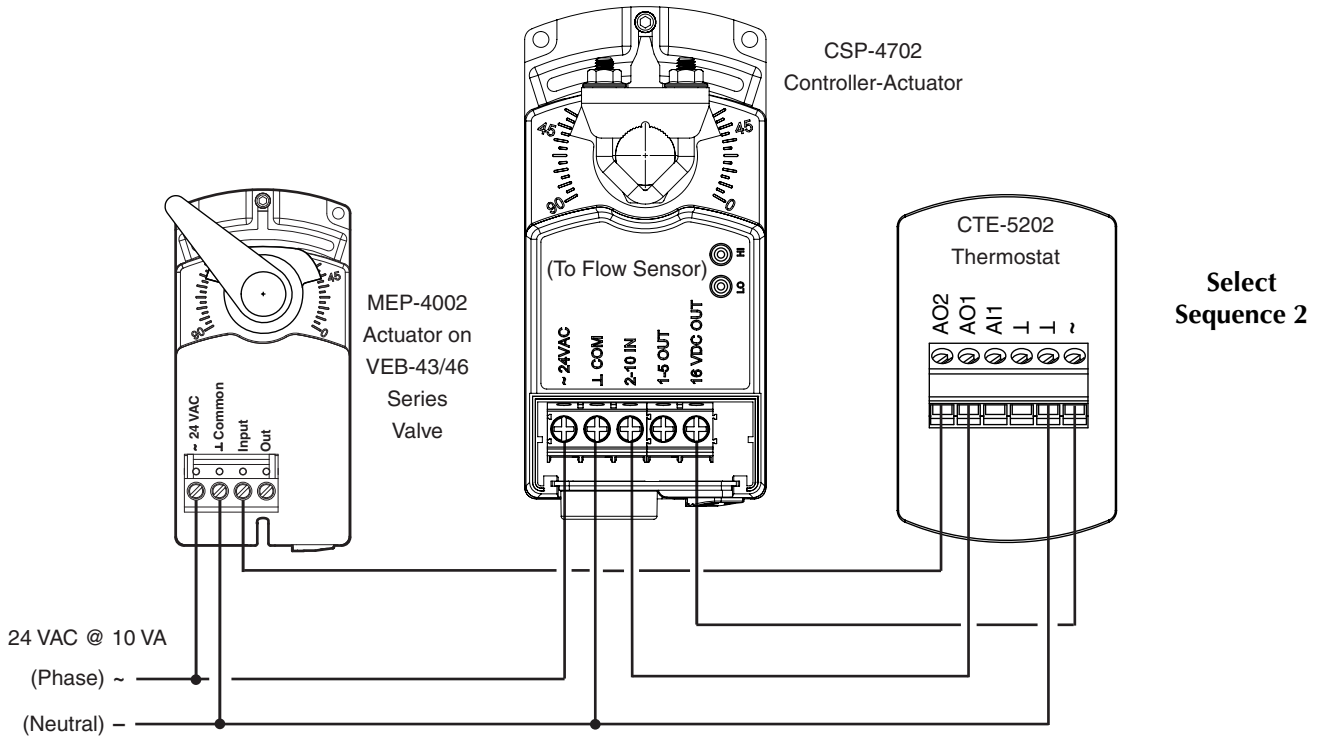

Fan Induction with 2-Stage Electric Heat

This fan induction application uses the thermostat with a REE-5002 relay module, a fan, and two coils (for two stages of reheat). The REE-5002 was designed primarily for use with VAV fan-powered induction boxes.

If the temperature drops below setpoint, the REE-5002 senses the decrease in voltage on AO2 and starts the fan. As the temperature continues to drop, the first stage of reheat begins, and the second stage of reheat follows if the thermostat is still not satisfied. The process reverses as the room temperature begins to rise.

Sequence 1 should be selected from the CTE-5202 SYSTEM menu. See [Change Configuration on page 6](#).

NOTE: The REE-5002 provides the fan an adjustable start point between 3 and 8 VDC, with a 1 VDC switching differential. The “X” Terminal is used for measuring fan trip voltage. See also the [REE-5002 Installation Guide](#).

NOTE: Triac outputs on the REE-5002 are for 24 VAC loads only. The phase side of the transformer connects to the “common” side of the load (contactors).

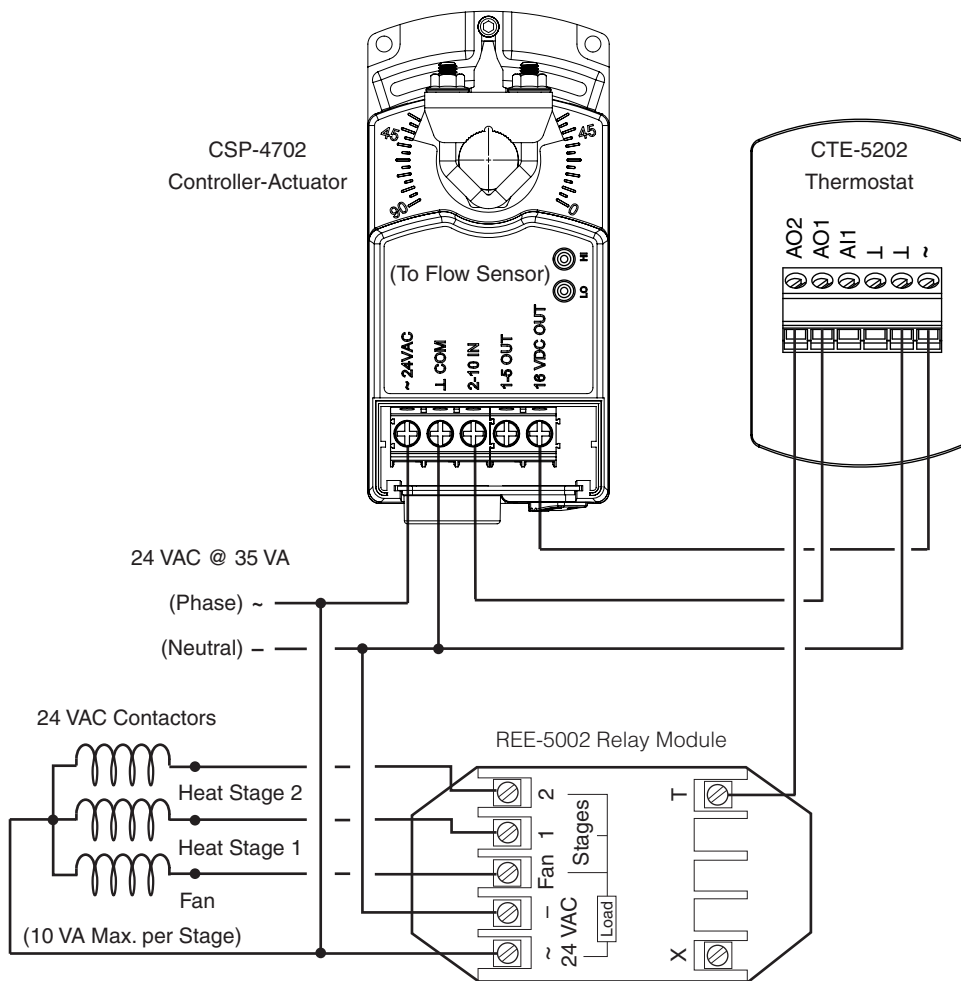
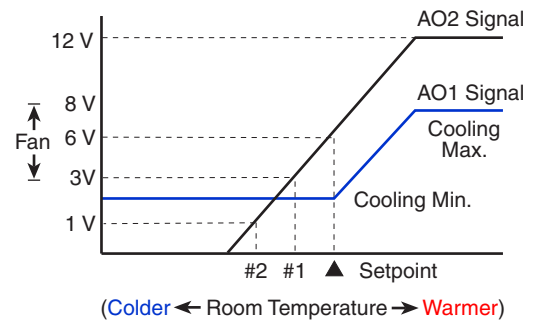

Select Sequence 1

Dual Duct, Minimum Air from Cold Duct

Dual duct applications can use two CSP-4702s with a CTE-5202. In this application, the CSP-4702s are mounted separately on the cold and hot air duct dampers with each using its own flow sensor.

The cold-deck controller receives the AO1 signal from the thermostat while the hot-deck controller

receives its requested flow signal from AO2. Both CSP-4702s can be set independently for minimum and maximum flow settings.

Select Sequence 3 (from the CTE-5202 *SYSTEM* menu). See [Change Configuration on page 6](#).

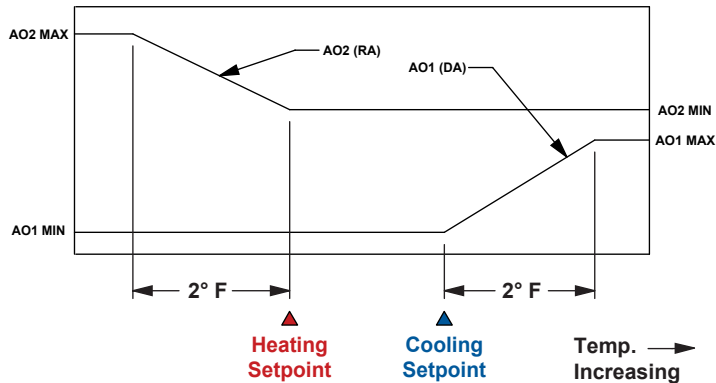
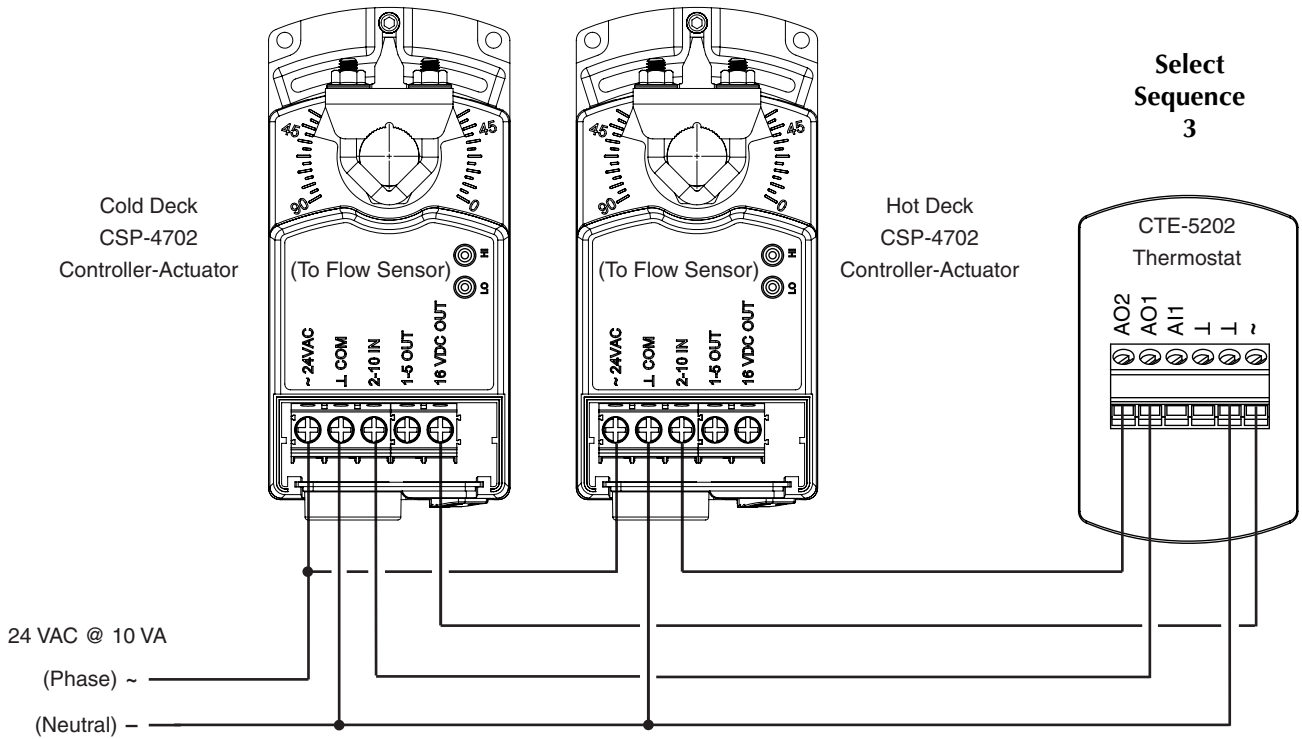

Pressure Independent VAV

Applications with CSP-5001/5002

This section gives sample applications for using the CTE-5202 as a substitute for the CTE-5100 series thermostats with the CSP-5001/5002 VAV controller-actuator. (For replacement of the CSP-500x by the CSP-4702, see [Replacing a CSP-5001/5002 on page 21.](#))

Factory-set rotation direction of the CSP-5001 is CCW to close (CW to open or CW with increasing voltage), and the CSP-5002's is CW to close (CCW to open or CCW with increasing voltage). The direction can be reversed by changing the position of a jumper. The CSP-5001 (with default direction) is used in the examples of this section.

See also the [CSP-5001/5002 Applications Guide](#).

Concerning replacements of the CTE-510x thermostats, see [Cross-References on page 8](#).

To manually **open** the box, remove wiring from Terminal IN and jumper Terminal IN to Terminal 16 VDC. This will tell unit to control at 3300 fpm (full airflow), the green LED should turn on, and the box should drive open).

To manually **close** the box, remove wiring from Terminal IN, and jumper Terminal IN to Terminal -. This will tell unit to control at zero fpm (no airflow), the red LED should be on and the box should drive closed.



NOTE: If using an SSS-101x sensor (instead of an SSS-100x), the 3/8" tubing and adapters shown in the illustration are unnecessary.

NOTE: See also [Auto and Override \(to Fully Closed or Fully Open\) on page 35](#). Full rotation may take five to six minutes because the actuator rotates at 18° per minute.

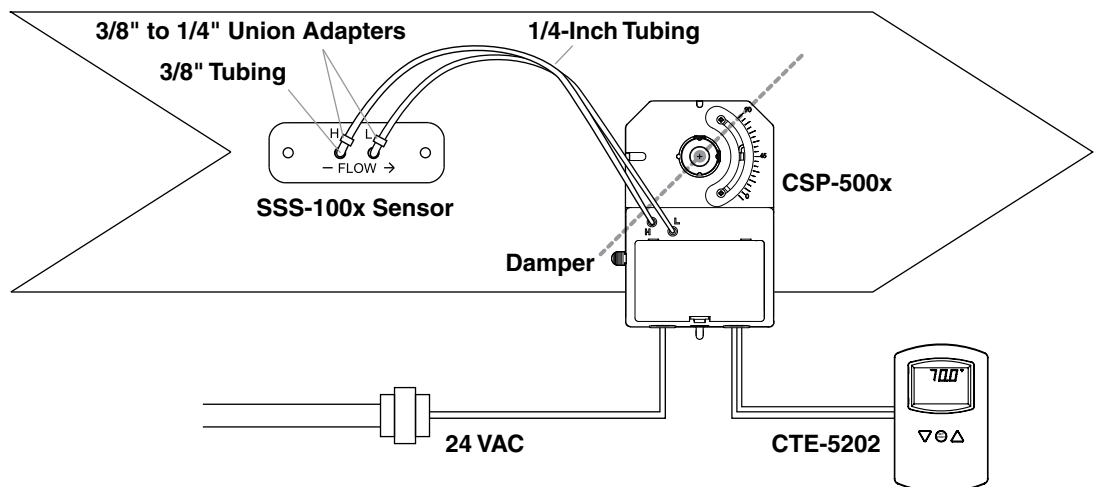

Cooling or Heating

CTE-5202 thermostats can use CSP-5000 series electronic VAV controllers to operate damper boxes in the pressure-independent VAV system. As shown in the diagram, a “requested flow” voltage signal (AO1) is connected to the CSP-5001 to adjust airflow from minimum to maximum flow according to space demand. Minimum and maximum flow limit adjustments can be made at the thermostat or at the controller.

For **cooling**, select Sequence 1 (from the CTE-5202 SYSTEM menu). See [Change Configuration on page 6](#). (This replaces a CTE-5101 or a CTE-5015.)

For **heating**, connect a 5K to 10K ohm resistor between Common and AI1. Select Sequence 1 and lower the Changeover to the lowest setting (55° F). See [Change Configuration on page 6](#). The resistor simulates a changeover sensor and puts the thermostat in Reverse Acting mode. (This replaces a CTE-5102 with Reverse Acting reset.)

NOTE: If the resistor value is too high, the thermostat will not go into RA mode. If the resistor value is too low, the thermostat may go into setback mode.

(See also the Cooling or Heating section in the [CSP-5001/5002 Applications Guide](#).)

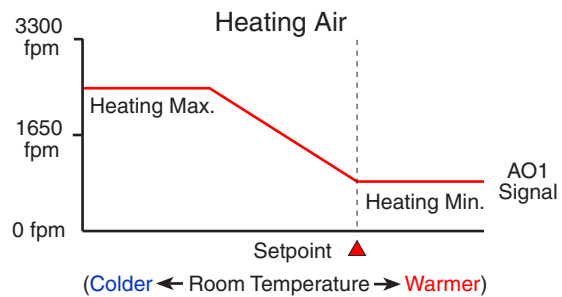
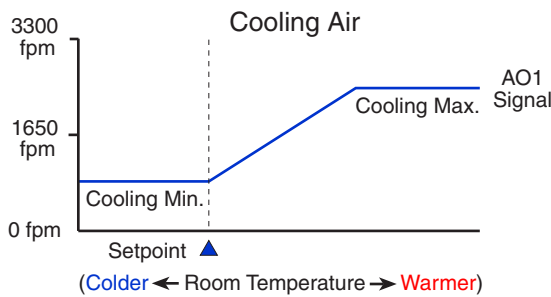
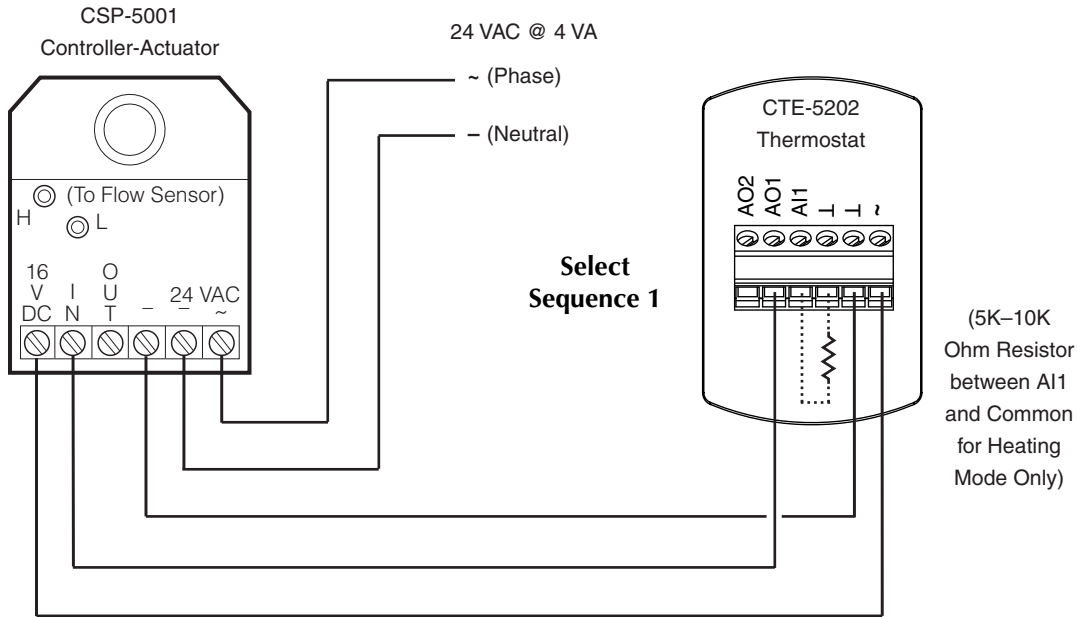

Auto and Override (to Fully Closed or Fully Open)

Adding a SPDT relay or switch enables overriding the air flow to fully open or fully closed. (Otherwise the examples below are the same as the **cooling** configuration in [Cooling or Heating on page 34.](#))

The “Override to Fully Closed” wiring diagram below allows the CTE-5202 thermostat to control the CSP-5001 controller as normal (auto) or override the flow setting to fully closed.

The SPDT relay selects one of the two modes (Auto/ Fully Closed). In the relay position shown below, the controller will override the flow setting. (Jumping “-” and “IN” drives the CSP-5001 fully closed.)

NOTE: If a minimum limit was set in the CSP-500x controller, the damper will only close to the minimum limit setting.

When the relay switches to Auto, the thermostat will then control the VAV box based on demand.

The “Override to Fully Open” wiring illustration below allows the CTE-5202 thermostat to control the CSP-5001 controller as normal (Auto) or override the flow setting to fully open.

In the relay position shown, the controller will override the flow setting. (Jumping “16 VDC” and “IN” drives the CSP-5001 fully open.)

NOTE: If a maximum limit was set in the CSP-500x controller, the damper will only open to the maximum limit setting.

When the relay switches to Auto, the thermostat will control the VAV box based on demand.

(See also the Auto, Override to Fully Closed, or Override to Fully Open section with a CTE-5101 in the [CSP-5001/5002 Applications Guide.](#))

Override to Closed

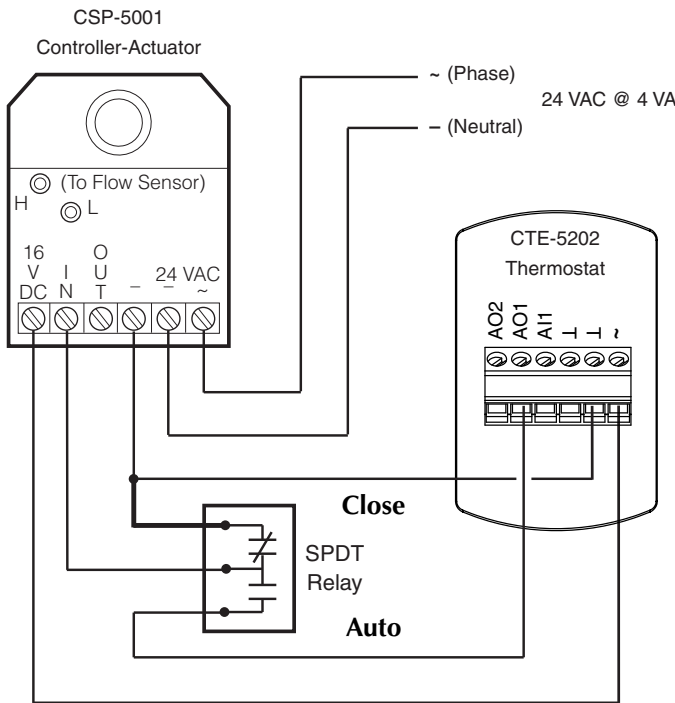

Override to Open

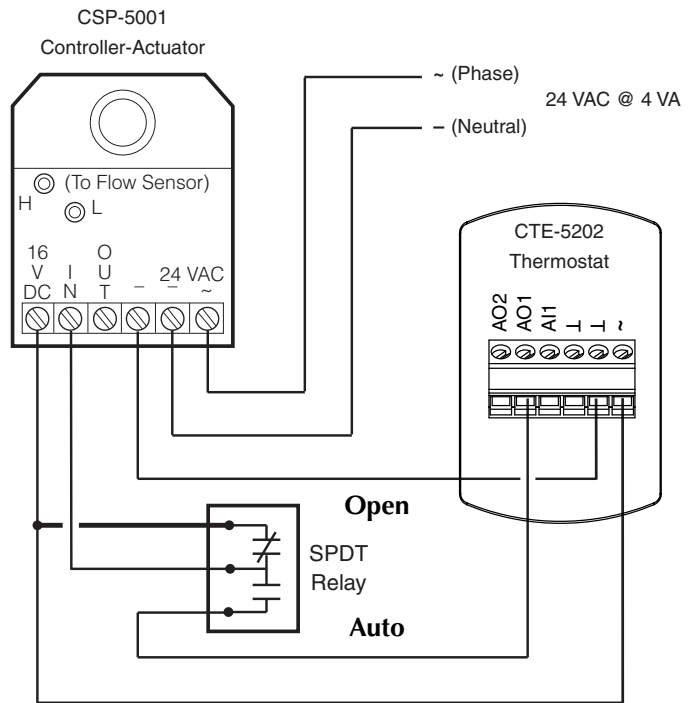

Select Sequence 1

Cooling with 3-Stage Reheat

This application uses a CSP-5001 along with an REE-5001 relay module and three 24 VAC contactors for three stages of reheat.

As the temperature drops below setpoint, the first stage of reheat begins. As the temperature continues to drop, the second stage and later the third stage begin as needed.

Select Sequence 2 (from the CTE-5202 *SYSTEM* menu), with or without Auxiliary Flow (*AUX* in *LIMITS* menu). See [Change Configuration on page 6](#).

(See also the Cooling with 3-Stage Reheat section with a CTE-5104 for auxiliary flow or a CTE-5103 without auxiliary flow in the [CSP-5001/5002 Applications Guide](#).)

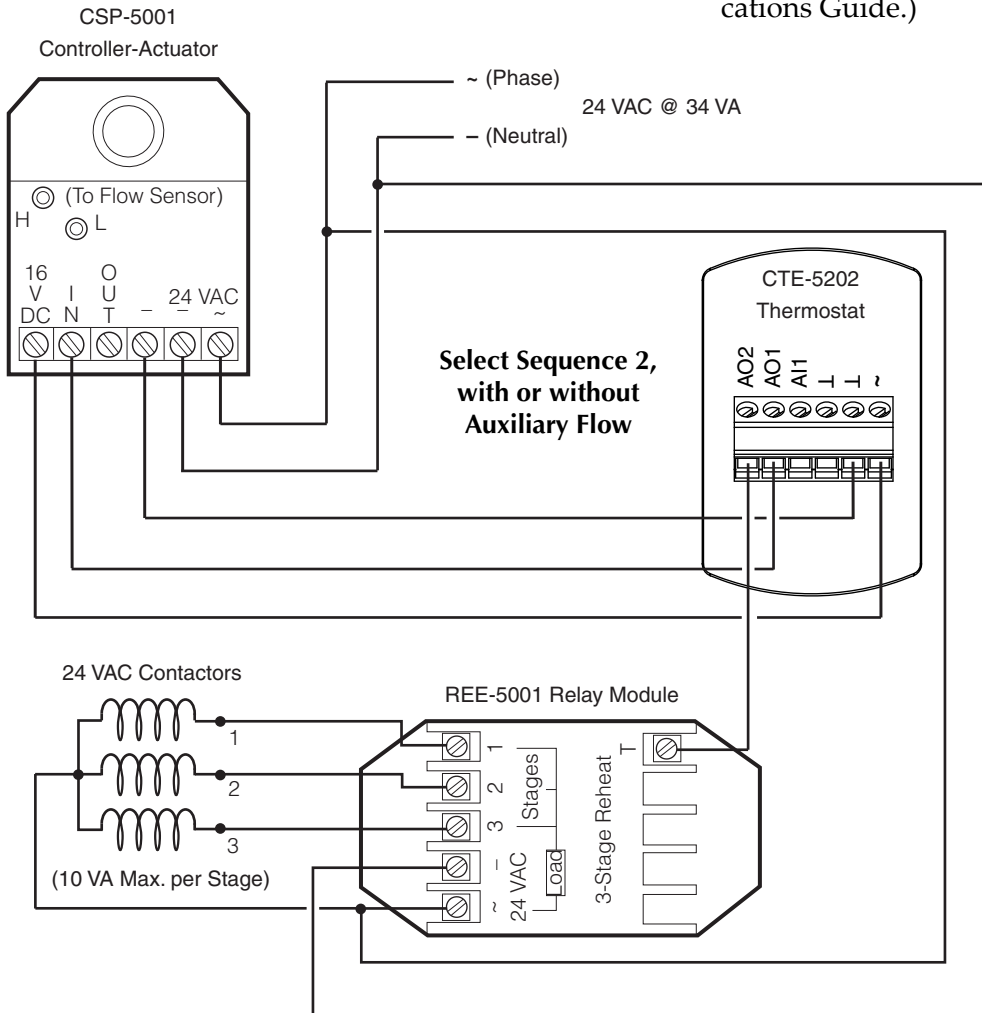

NOTE: Triac outputs on the REE-5001 are for 24 VAC loads only. The phase side of the transformer connects to the "common" side of the load (contactors).

NOTE: See also the [REE-5001 Installation Guide](#).

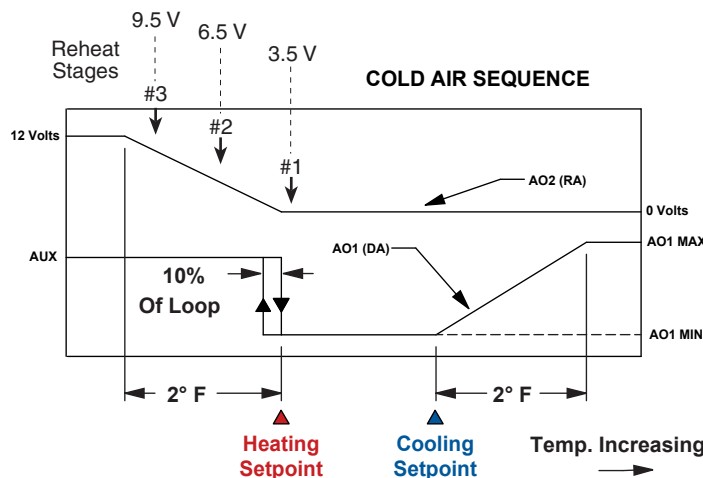

Cooling with 3-Stage Reheat and Night Setback/Setup

This configuration is the same as on the previous page except for the addition of an SPST relay or switch. See [Cooling with 3-Stage Reheat on page 36](#).

The switch or relay is driven by a night/unoccupied setback/setup signal from other equipment not shown. When the contact is closed (e.g., by a timer), setback/setup mode initiates, changing the setpoint by the offset selected in *ADVANCE > SETBACK* menu. See [Change Configuration on page 6](#) and [Unoccupied/Standby Setback on page 5](#).

NOTE: The night/unoccupied setback offset does not apply to morning warm-up.

NOTE: This configuration requires the system fan to be on during setback/setup mode.

NOTE: Triac outputs on the REE-5001 are for 24 VAC loads only. The phase side of the transformer connects to the “common” side of the load (contactors).

NOTE: See also the [REE-5001](#) Installation Guide.

(See also the Cooling with 3-Stage Reheat and Night Setback/Setup section with a CTE-5104 in the [CSP-5001/5002](#) Applications Guide.)

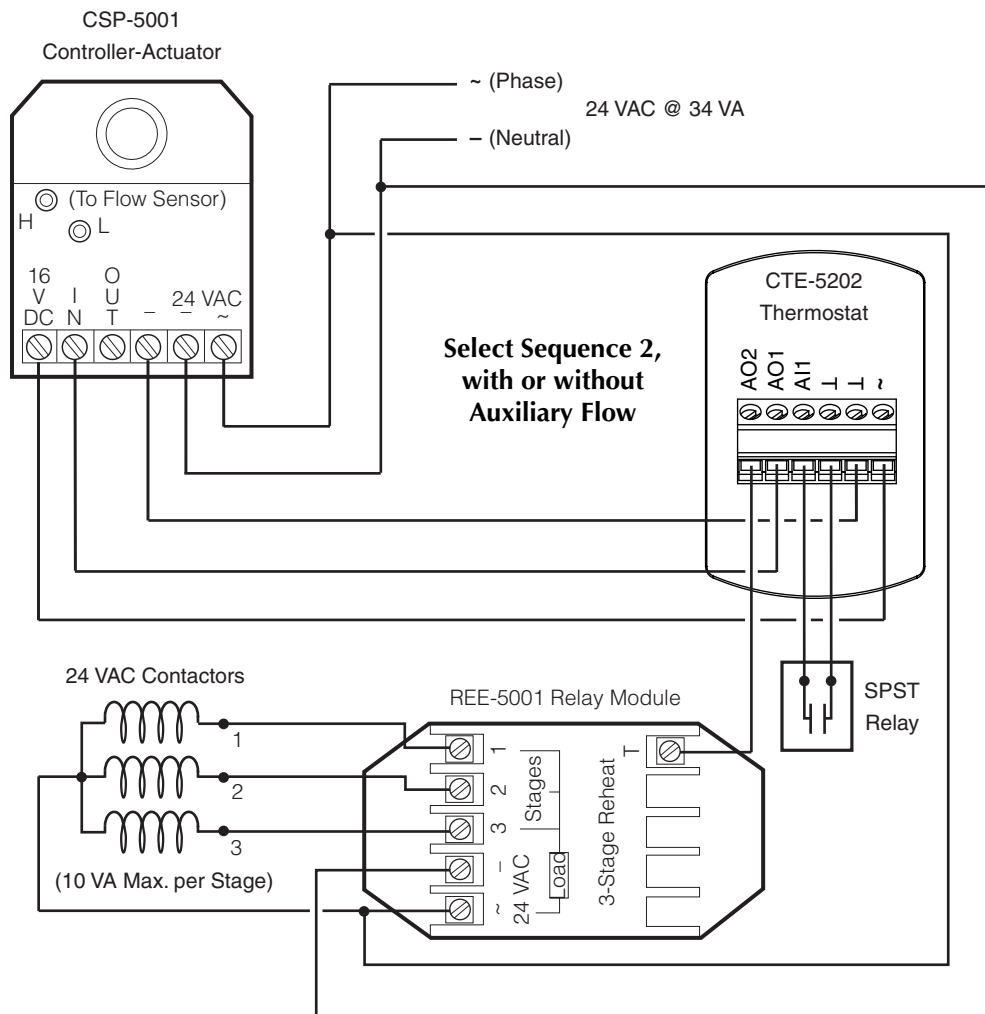

Cooling with Heating Changeover

Using a duct sensor with the CTE-5202, an automatic changeover is provided for heating/cooling applications. The duct sensor will switch the thermostat between cooling and heating modes based on the temperature of the duct supply air. A duct temperature higher than changeover temperature switches control to heating mode, and a temperature lower than changeover temperature switches control to cooling mode.

Select Sequence 1 (from the CTE-5202 *SYSTEM* menu). See *Change Configuration on page 6* and *Hot/Cold Changeover on page 5*. The default changeover temperature is 77° F, configurable from 55 to 85° F in the CTE-5202 *ADVANCE* menu.

NOTE: The CTE-5202 uses the 16 VDC power from the CSP-5001. If replacing a CTE-5103 thermostat as described in the Cooling and Heating Changeover section of the **CSP-5001/5002 Applications Guide**, the REE-1005 relay module is no longer needed with the CTE-5202.

NOTE: If using an existing TTE-2001 duct sensor/transmitter (instead of an STE-140x duct sensor), connect to Terminals 1 and 2.

NOTE: Minimums can be set at zero air flow, but a minimum of greater than zero is required for a quick changeover.

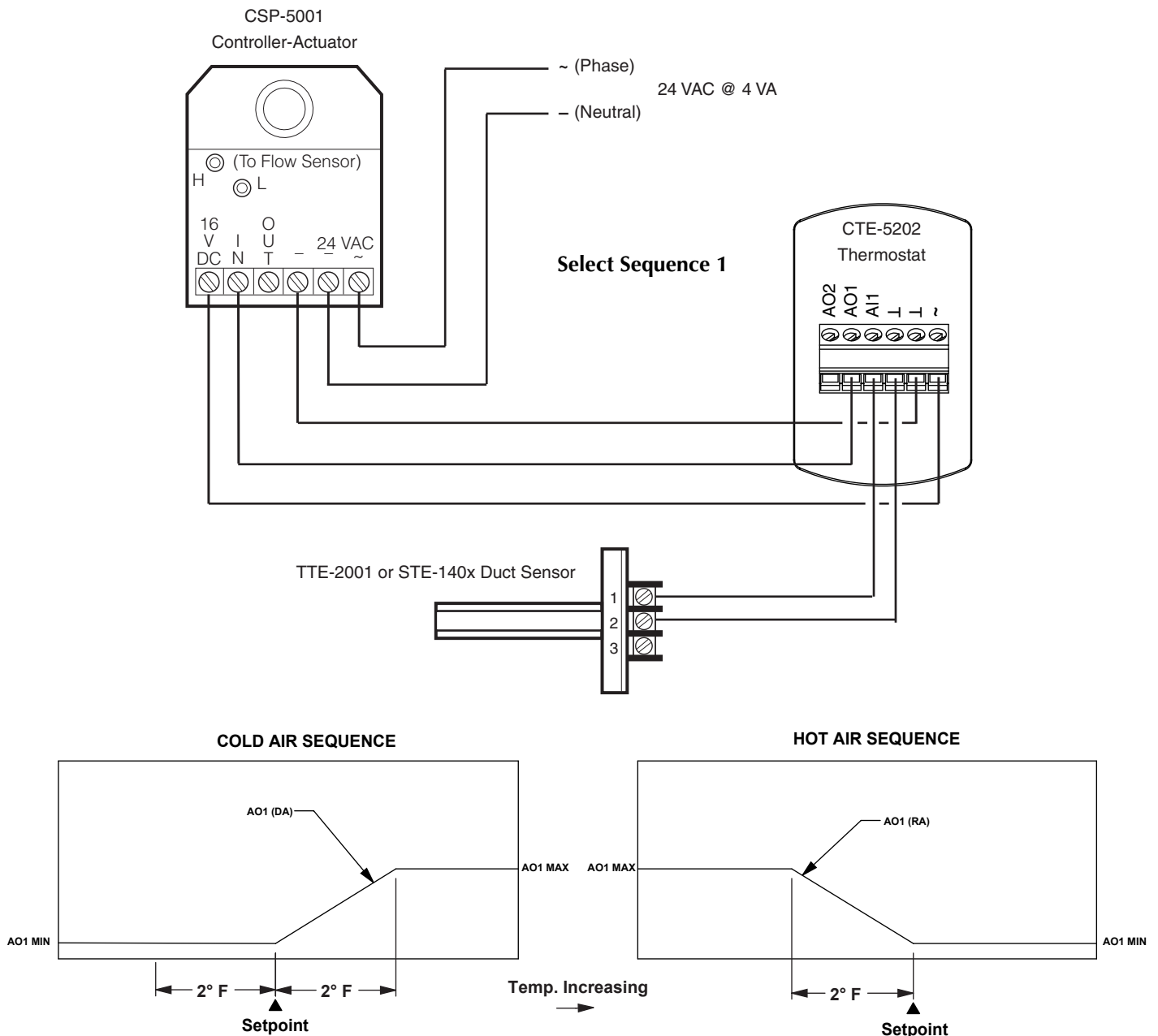

Cooling with Heating Changeover and Electric Reheat

This configuration is the same as the previous page except for the addition of an REE-5001 relay module connected to AO2 (for three stages of reheat) and selecting Sequence 2 from the CTE-5202 SYSTEM menu. See [Change Configuration on page 6](#), [Hot/Cold Changeover on page 5](#) and [Cooling with Heating Changeover on page 38](#). See also [Cooling with 3-Stage Reheat on page 36](#).

NOTE: The CTE-5202 uses the 16 VDC power from the CSP-5001. If replacing a CTE-5103 thermostat as described in the Cooling with Heating Changeover and Electric Reheat section of the [CSP-5001/5002 Applications Guide](#), the REE-1005 relay module is no longer needed with the CTE-5202.

NOTE: If using an existing TTE-2001 duct sensor/transmitter (instead of an STE-140x duct sensor), connect to Terminals 1 and 2.

NOTE: Minimums can be set at zero air flow, but a minimum of greater than zero is required for a quickchangeover.

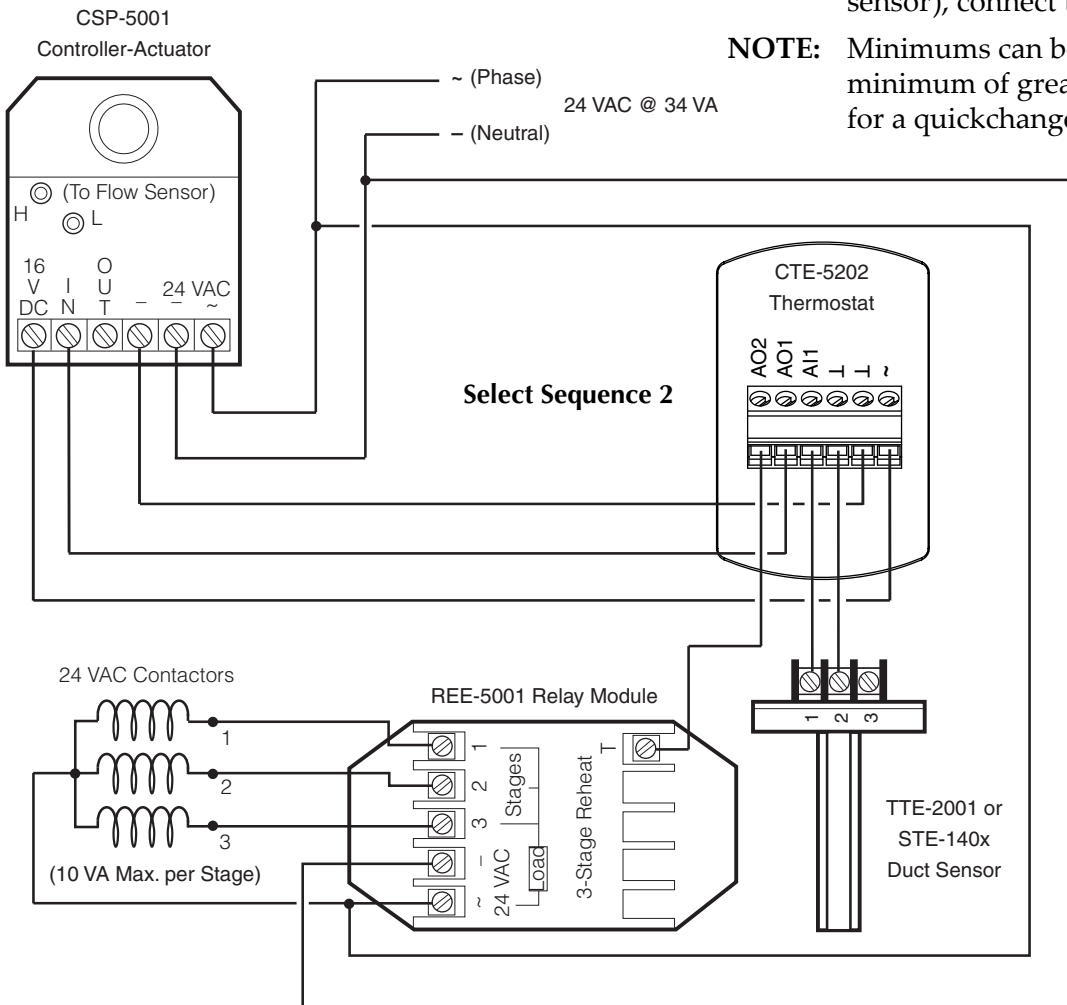

NOTE: Triac outputs on the REE-5001 are for 24 VAC loads only. The phase side of the transformer connects to the "common" side of the load (contactors).

NOTE: See also the [REE-5001 Installation Guide](#).

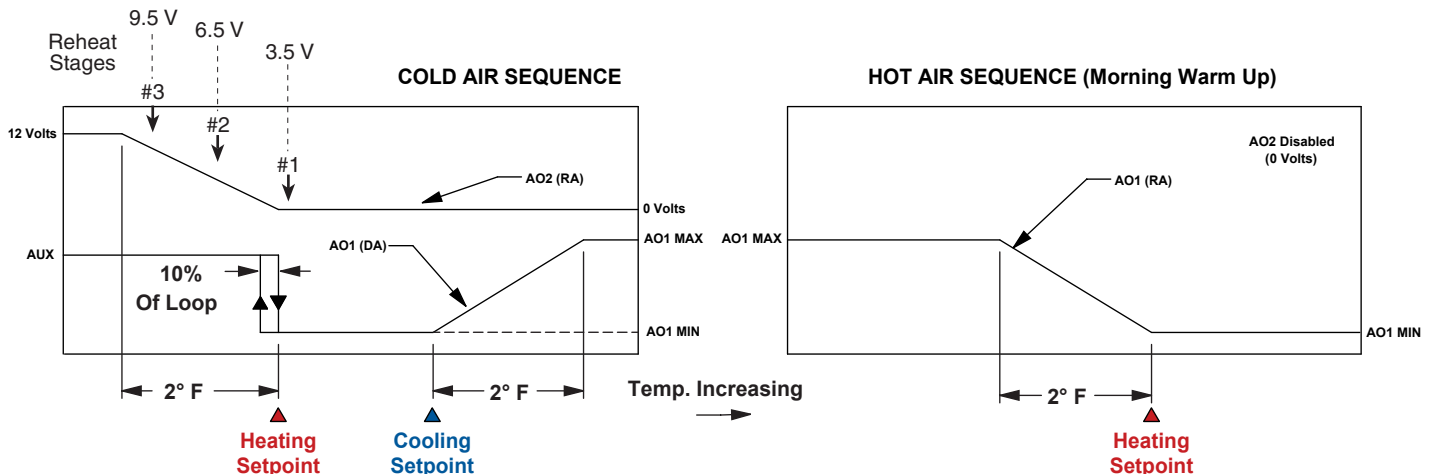

Cooling with Heating Changeover and Hot Water Reheat

See [Cooling with Heating Changeover and Electric Reheat on page 39](#). This application operates the same except for using a hot water valve instead of electric heating elements for reheat (a VEB-43/46 series valve in place of the REE-5001 relay).

To retrofit a CTE-510x thermostat in an existing installation with a different valve than a VEB-43/46 series, see the corresponding installation guide for that valve and actuator.

When there is hot air in the duct, changeover initiates, allowing the heating signal from AO1 to control

airflow and AO2 to control the valve. When there is a call for heat, the thermostat modulates the hot water valve.

NOTE: If using an existing TTE-2001 duct sensor/transmitter (instead of an STE-140x duct sensor), connect to Terminals 1 and 2.

NOTE: See also the Cooling with Heating Changeover and Hot Water Reheat section with a CTE-5103 in the [CSP-5001/5002 Applications Guide](#).

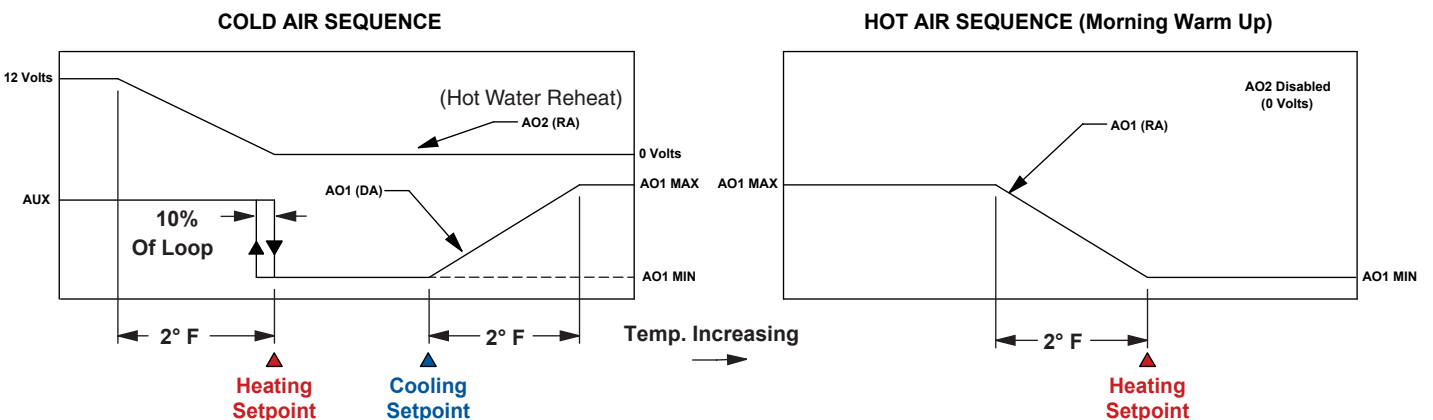
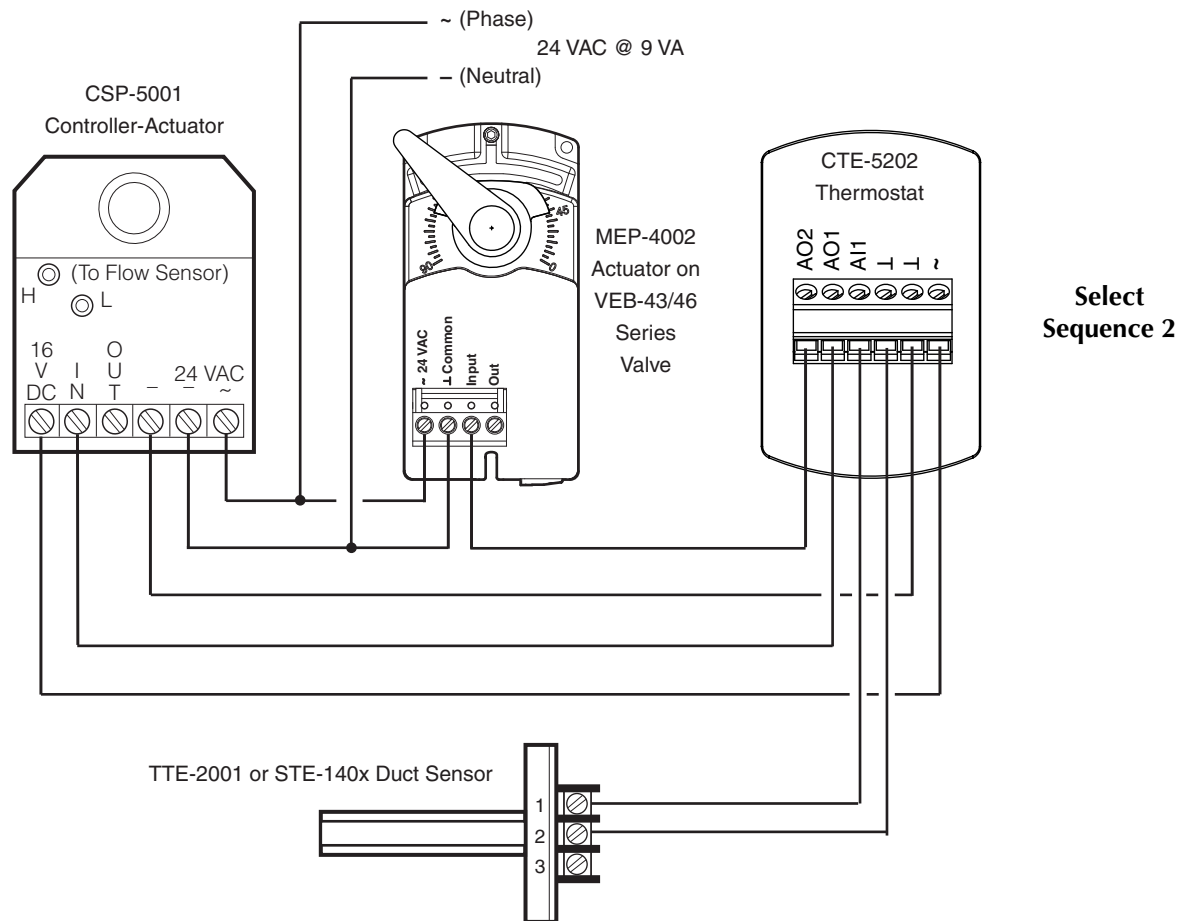

Cooling with Hot Water Reheat

See [Cooling with 3-Stage Reheat on page 36](#). This application operates the same except for using a hot water valve instead of electric heating elements for reheat (a VEB-43/46 series valve in place of the REE-5001 relay).

To retrofit a CTE-510x thermostat in an existing installation with a different valve than a VEB-43/46 series, see the corresponding installation guide for that valve and actuator.

AO1 controls airflow and AO2 controls the valve. When there is a call for heat, the thermostat modulates the hot water valve.

(See also the Cooling with Hot Water Reheat section with a CTE-5104 in the [CSP-5001/5002 Applications Guide](#).)

NOTE: See also the use of the CTE-5202 with discontinued VEP-12/22/34 series valves in [Cooling with Hot Water Reheat on page 50](#).

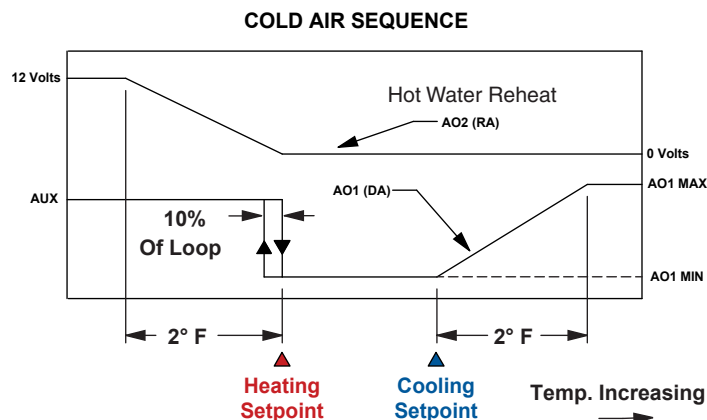
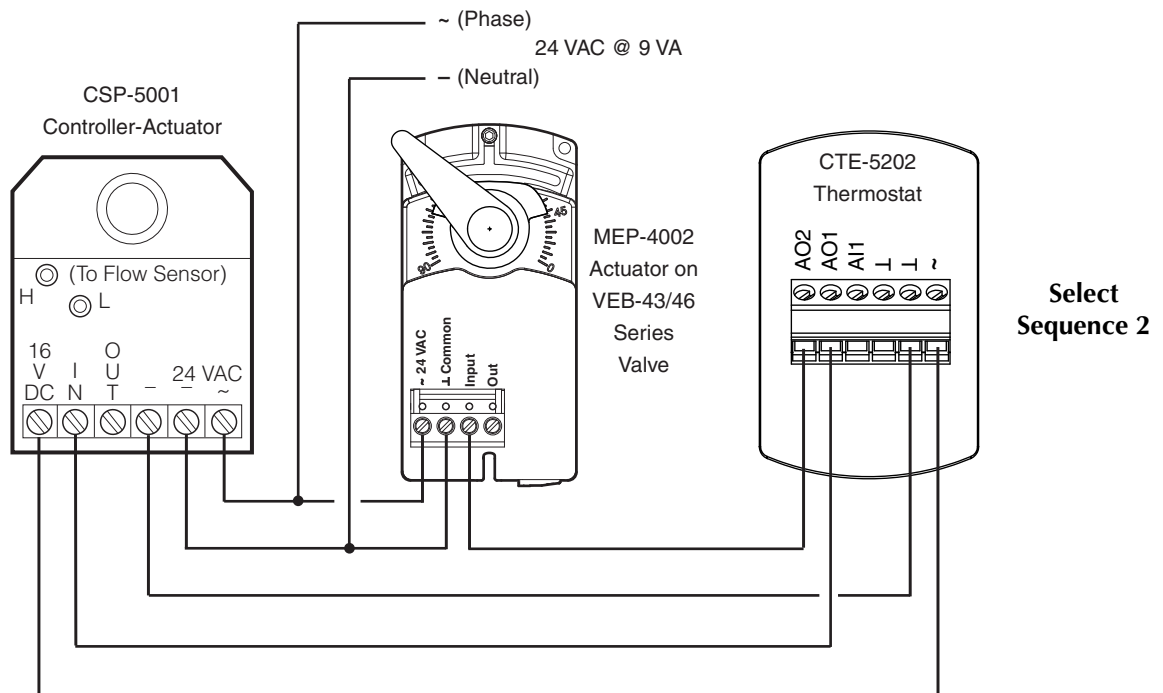

Fan Induction with 2-Stage Electric Heat

In this fan induction application, the CTE-5202 thermostat is used with a REE-5002 relay module, a fan, and two coils (for two stages of reheat). The REE-5002 was designed primarily for use with VAV fan-powered induction boxes.

If the temperature drops below setpoint, the REE-5002 senses the decrease in voltage on AO2 and starts the fan. As the temperature continues to drop, the first stage of reheat begins, and the second stage of reheat follows if the thermostat is still not satisfied. The process reverses as the room temperature begins to rise.

Sequence 1 should be selected from the CTE-5202 SYSTEM menu. See *Change Configuration on page 6*.

(See also the Fan Induction with 2-Stage Electric Heat section with a CTE-5101 in the [CSP-5001/5002 Applications Guide](#).)

NOTE: The REE-5002 provides the fan an adjustable start point between 3 and 8 VDC, with a 1 VDC switching differential. The “X” Terminal is used for measuring fan trip voltage. See the [REE-5002 Installation Guide](#) for details.

NOTE: Triac outputs on the REE-5002 are for 24 VAC loads only. The phase side of the transformer connects to the “common” side of the load (contactors).

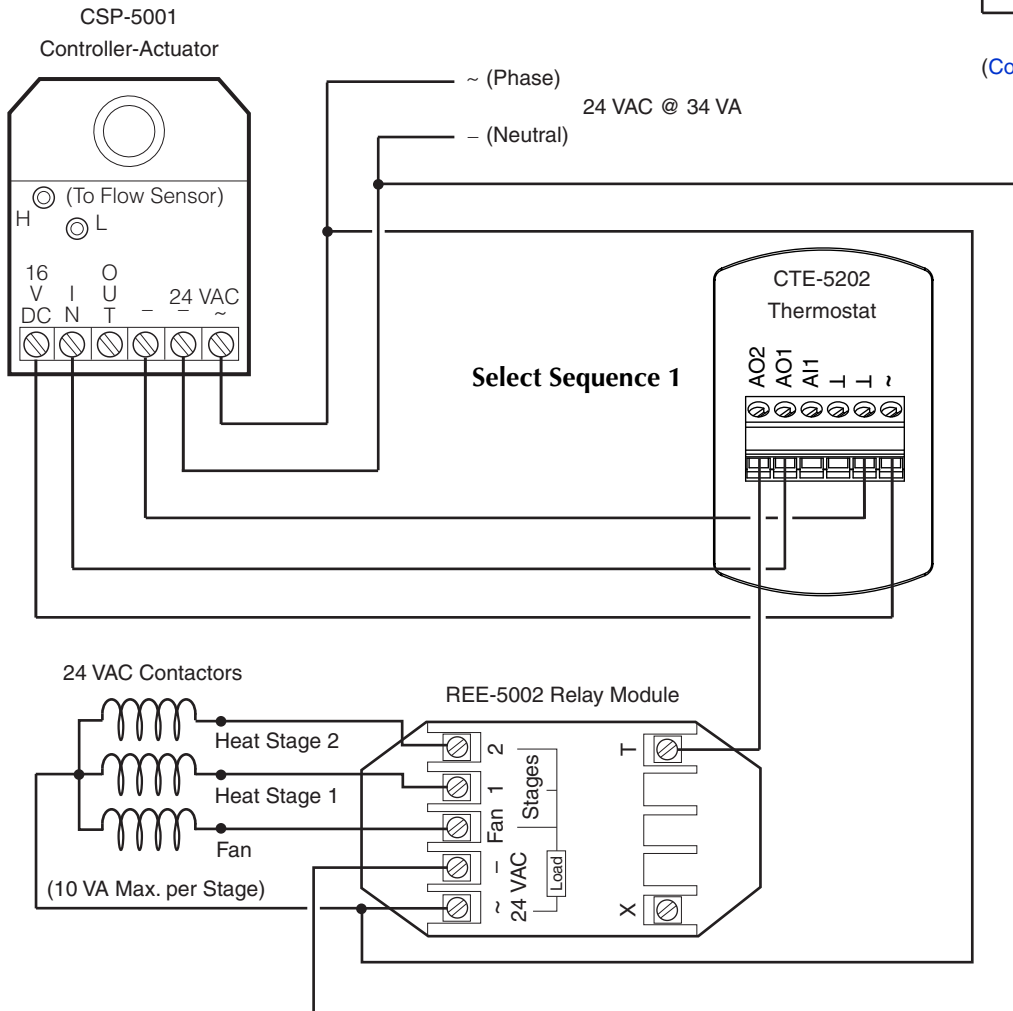
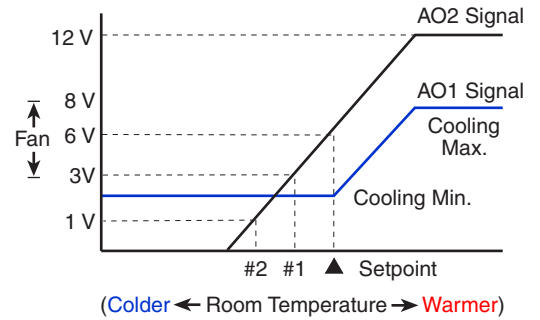

Dual Duct, Minimum Air from Cold Duct

Dual duct applications can use two CSP-5001s with a CTE-5202. In this application, the CSP-5001s are mounted separately on the cold and hot air duct dampers with each using its own flow sensor.

The cold-deck controller receives the AO1 signal from the thermostat while the hot-deck controller receives its requested flow signal from AO2. Both CSP-5001s can be set independently for minimum and maximum flow settings.

Select Sequence 3 (from the CTE-5202 *SYSTEM* menu). See [Change Configuration on page 6](#).

(See also the Dual Duct, Minimum Air from Cold Duct section with a CTE-5103 in the [CSP-5001/5002 Applications Guide](#).)

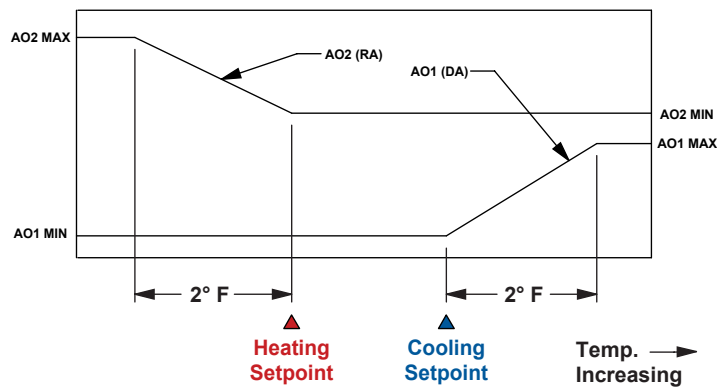
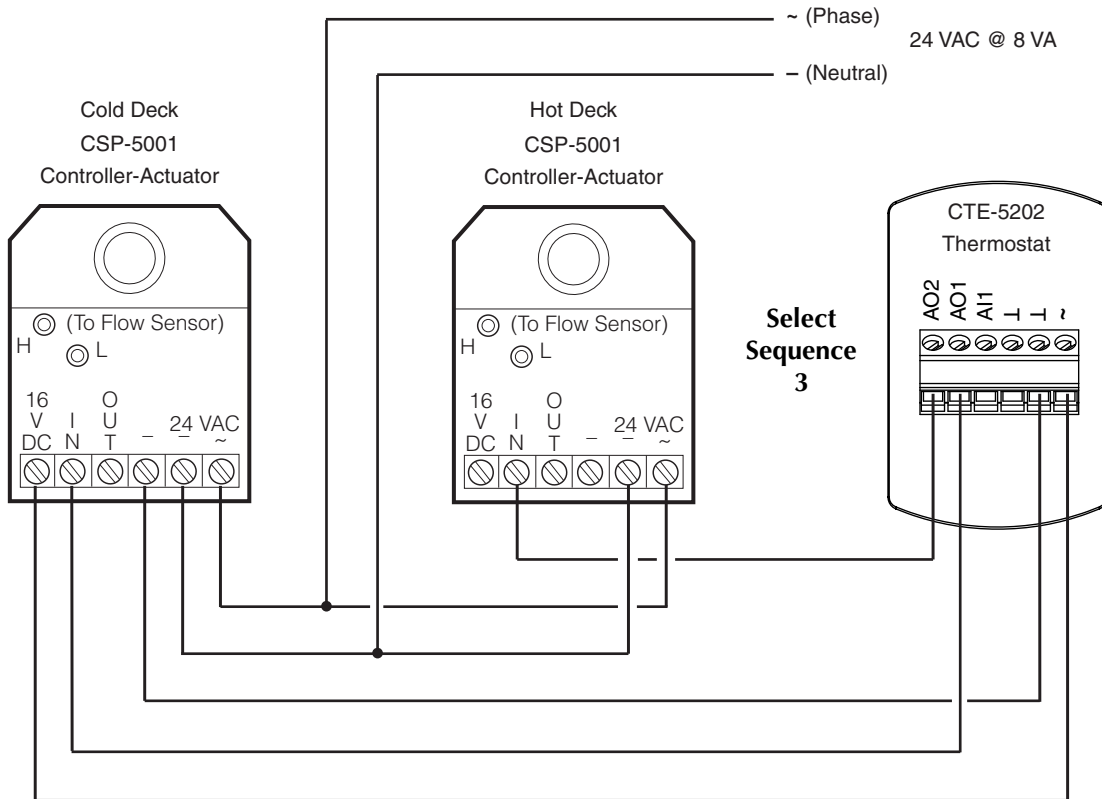

Pressure Independent VAV and CAV Applications with CEP/CSP-4000 Series

This section gives sample applications for using the CTE-5202 as a substitute for the CTE-1000 series thermostats with the CEP/CSP-4000 series VAV controller-actuators. (See also the [CEP-4000 Series Applications Guide](#). For replacement of the CxP-4xxx with the CSP-4702, see [Replacing a CEP-4xxx or CSP-40xx/42xx/44xx/46xx or CSE-484x on page 22.](#))

The CEP-4000 series uses SSE-1000/2000 series flow (“hot wire anemometer”) sensors. These sensors consists of two coils of wire mounted in the air stream: one monitors airflow, while the other is a reference used for duct temperature compensation. These sensors also include a temperature sensor for use with heating/cooling “changeover” applications (which requires an additional relay module).

The CSP-4000 series uses SSS-1000 series differential air flow sensors or a pitot tube instead of the SSE-1000/2000s. Otherwise wiring is the same as with the CEP-4000 series used in these examples.

To **manually drive** the controller/damper **open or closed** (with 24 VAC on terminals 9 and 10), remove the wiring to terminal 6, and temporarily jumper terminal 6 to:

- Terminal 5 (9.1 VDC) = Open
- Terminal 4 (- VDC) = Closed

NOTE: Full rotation may take five to six minutes because the actuator rotates at 18° per minute.

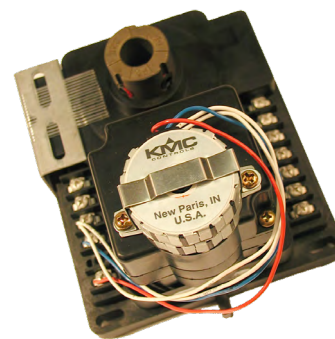

NOTE: For replacements of the CTE-1x1x thermostats, see [Cross-References on page 8.](#)

NOTE: The old CSP-40xx/42xx/44xx/46xx models were discontinued in Jan. 2014 and are very different from the new CSP-4702. See [Pressure Independent VAV Applications with CSP-4702 on page 20.](#)

▲ CAUTION

Do not short terminals 12 and 14, 4 and 5, or 2 and 4.

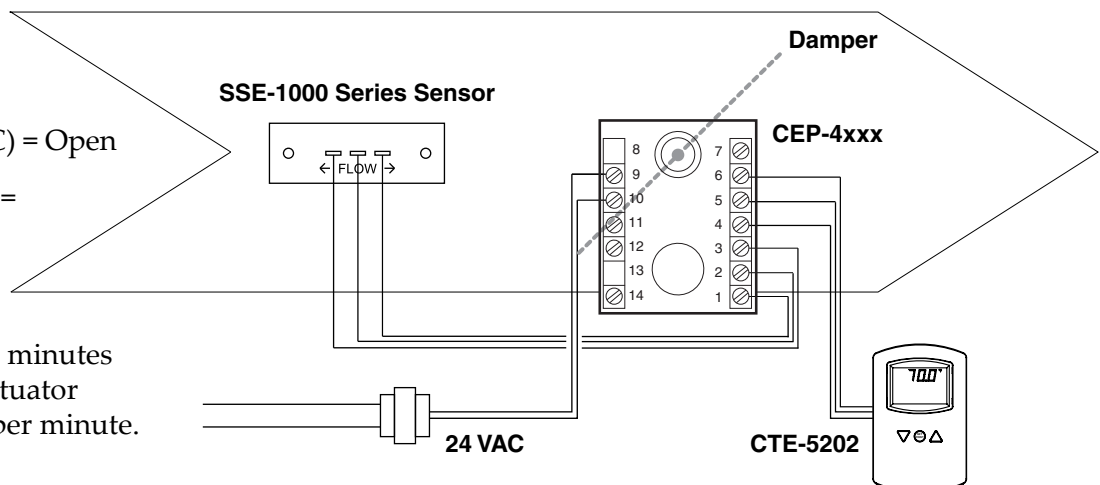

9.1 VDC vs. 24 VAC Power Options

The CTE-5202 can operate from the 9.1 VDC output supplied by the CEP/CSP-4xxx, but AO1 and AO2 will not be able to attain a full 6 VDC (e.g., a maximum of about 5.3 VDC) output to the 0–6 VDC CEP/CSP-4xxx inputs. This means the maximum air flow controlled by the CEP-4xxx can be only around 2000 fpm instead of 3000 fpm. However, this will still cover nearly all applications.

(See the Voltage/Velocity Correlation chart in the [CEP-4000 Series Applications Guide](#).)

If more than about 2000 fpm is required, use 24 VAC from a transformer to power the CTE-5202. **This can easily be done by connecting the ~ terminal on the CTE-5202 to Terminal 10 (24 VAC, phase) on the CEP-4xxx instead of Terminal 5 (+9.1 VDC).**

▲ CAUTION

Connect the CTE-5202 to the CEP-4xxx's Terminal 5 OR 10, but not jumpered to both.

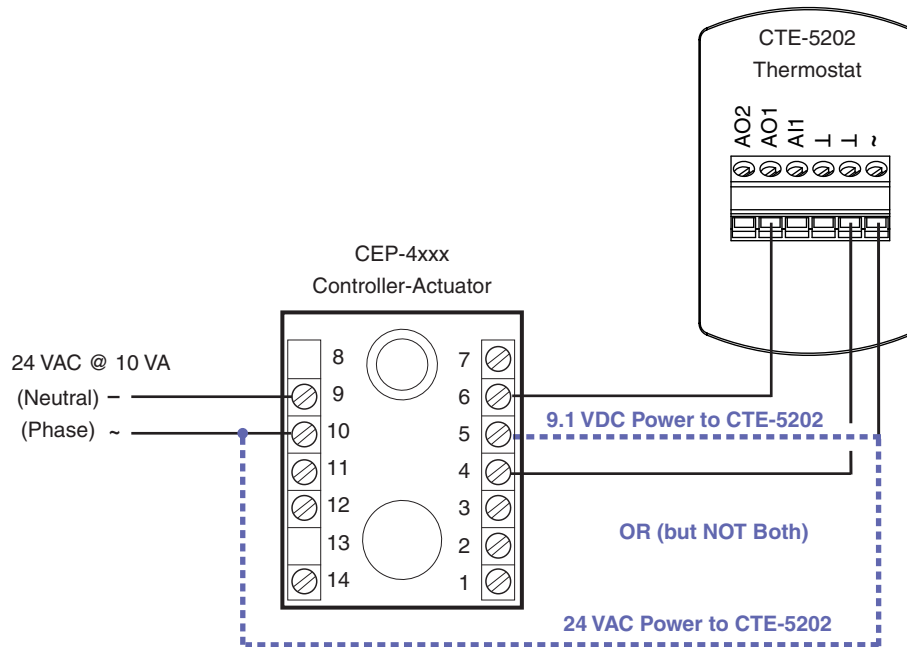

Cooling

CTE-5202 thermostats can use CEP/CSP-4000 series electronic VAV controllers to operate damper boxes in a pressure-independent VAV system. As shown in the diagram, a “requested flow” voltage signal (AO1) is connected to the CEP-4xxx to adjust airflow from minimum to maximum flow according to space demand. Minimum and maximum flow limit adjustments can be made at the thermostat or at the controller.

Select Sequence 1 (from the CTE-5202 *SYSTEM* menu). See *Change Configuration on page 6*. (This replaces a CTE-1001/1101/5001/5011 with Direct Acting reset.)

(See also the Cooling section in the *CEP-4000 Series Applications Guide*.)

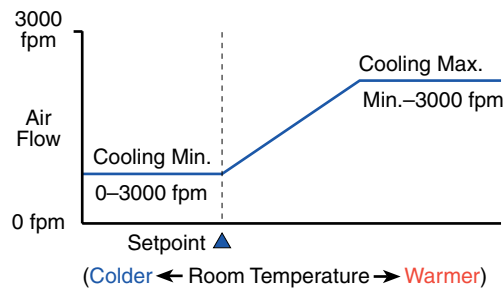
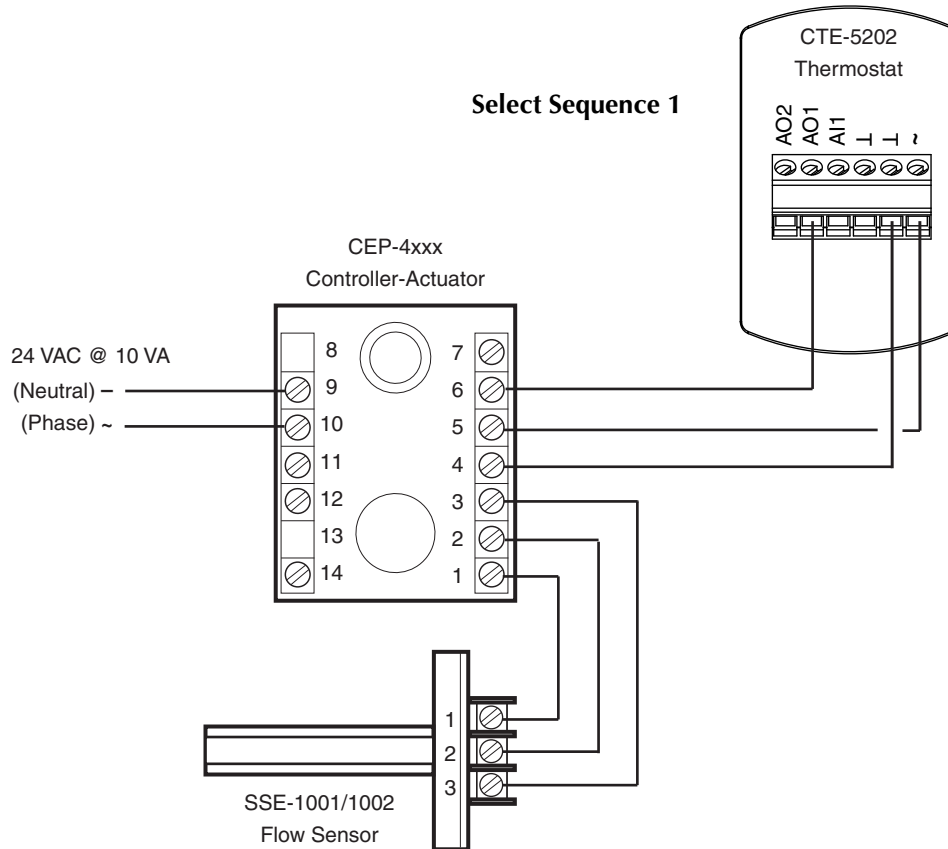

Cooling with Morning Warm-Up

Using the thermistor in an SSE-2001/2002 sensor enables the sensing of morning warm-up, and adding a SPDT relay or switch enables overriding the air flow to fully open for morning warm-up. Otherwise the example below is the same as the configuration in [Cooling on page 46](#).

The SPDT relay selects one of the two modes (Auto or Fully Open). Terminal 6 on the CEP-4xxx is

connected to either Terminal 5 (Fully Open) or to AO1 on the CTE-5202 (Auto, the default). When Terminal 6 is connected to Terminal 5, the 9.1 VDC causes full flow.

(See also the Cooling with Morning Warm-Up section in the [CEP-4000 Series Applications Guide](#).)

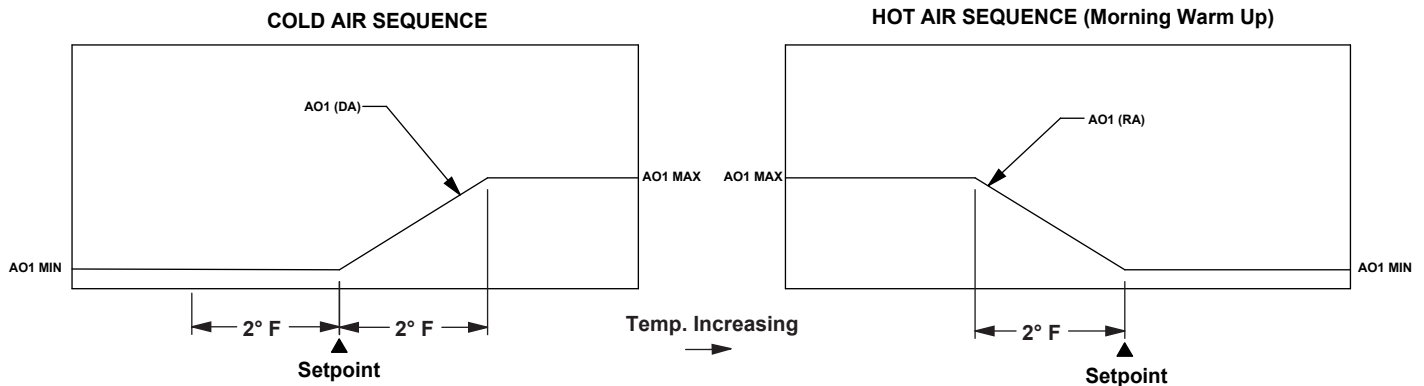
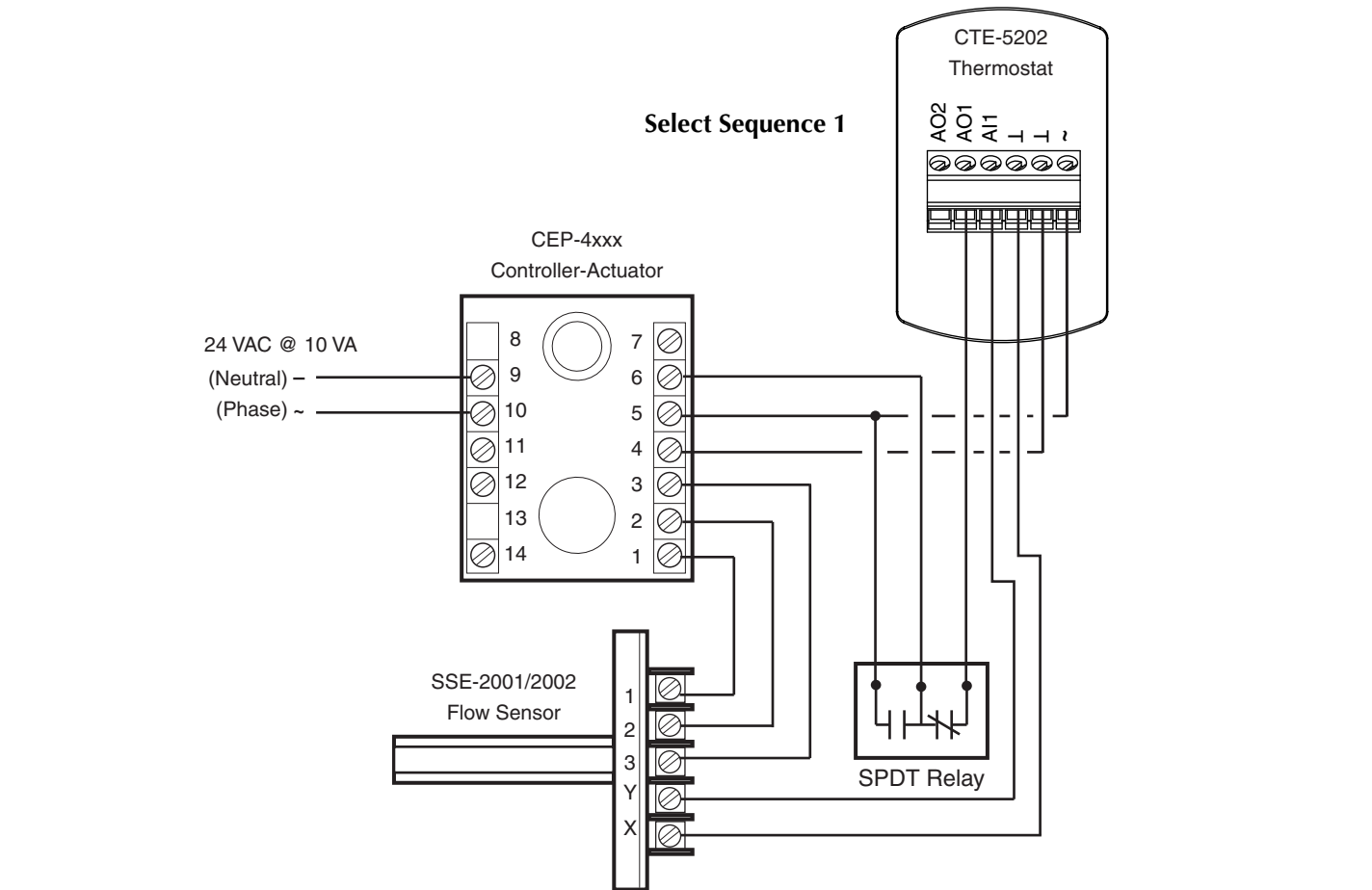

Cooling with 3-Stage Reheat

The application below uses an SSE-1000 series sensor, an REE-4001/5001 relay module, and three 24 VAC contactors for three stages of reheat.

The transformer must supply a minimum of 10 VA plus the requirements for the reheat contactor coils (10 VA maximum per stage).

As the temperature drops below setpoint, the first stage of reheat begins. If the temperature continues to drop, the second stage begins, and finally the third stage if necessary.

Select Sequence 2 (from the CTE-5202 SYSTEM menu). See [Change Configuration on page 6](#). (This replaces a CTE-1004 or a CTE-5002/5012 thermostat.)

If no Auxiliary Flow is desired, set *AUX FLOW* to 0 in the LIMITS menu.)

NOTE: Triac outputs on the REE-4001/5001 are for 24 VAC loads only. The phase side of the transformer connects to the "common" side of the load (contactors).

NOTE: See also the [REE-4001 Installation Guide](#) and/or [REE-5001 Installation Guide](#).

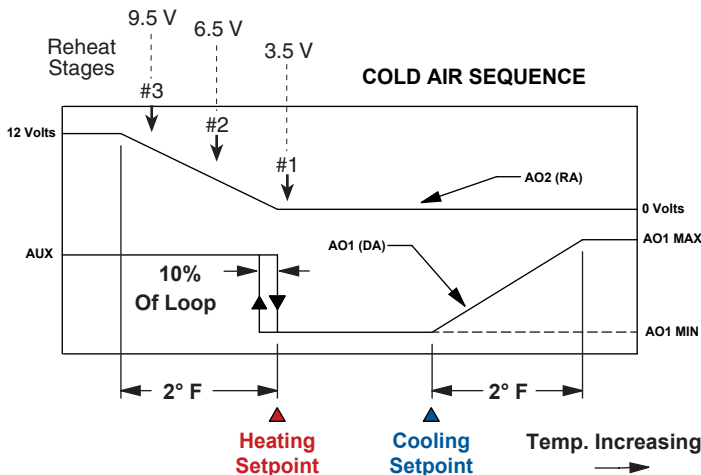
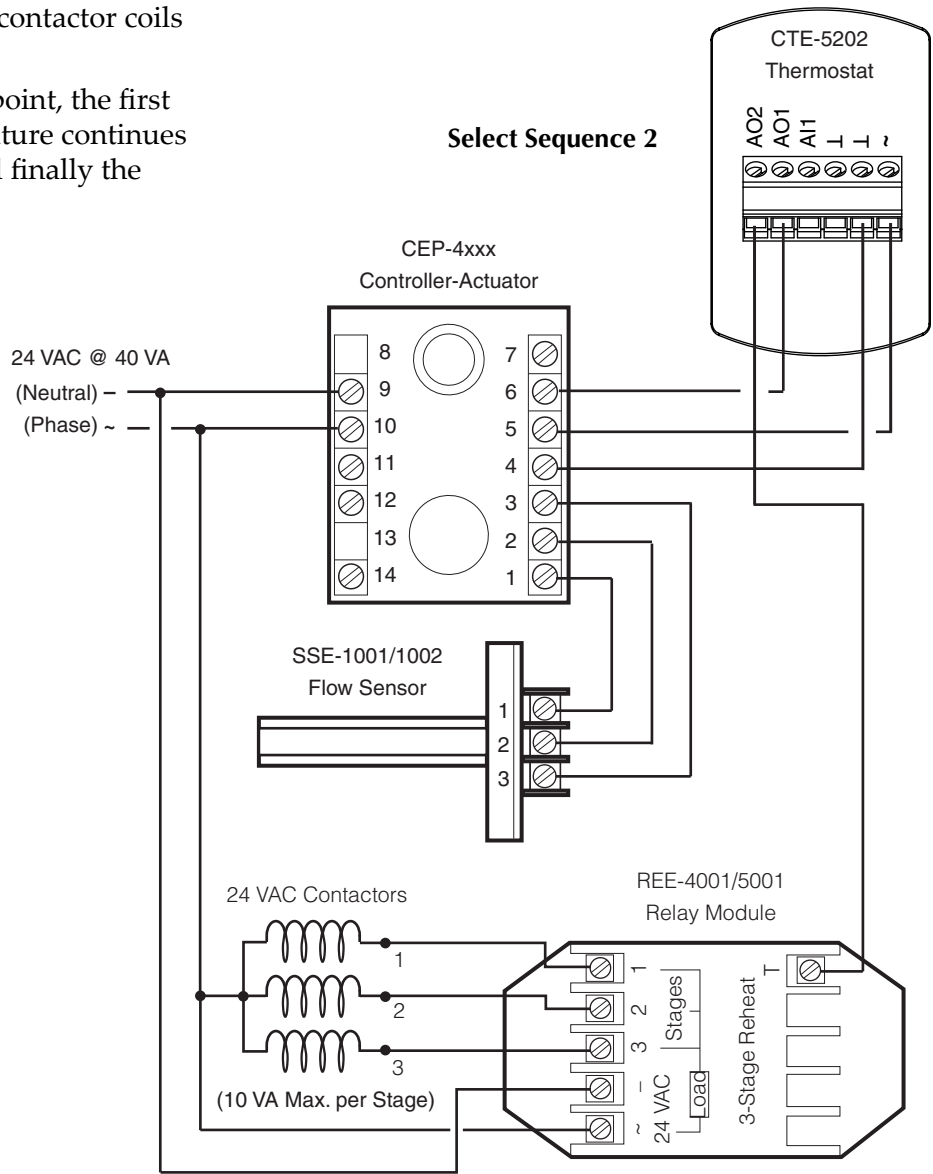

Cooling with Heating Changeover

Using a duct sensor with the CTE-5202, an automatic changeover is provided for cooling/heating applications. The duct sensor will switch the thermostat between cooling and heating modes based on the temperature of the duct supply air. A duct temperature higher than changeover temperature, switches control to heating mode, and a temperature lower than changeover temperature, switches control to cooling mode.

Select Sequence 1 (from the CTE-5202 *SYSTEM* menu). See *Change Configuration on page 6* and *Hot/Cold Changeover on page 5*. The default changeover temperature is 77° F, configurable from 55 to 85° F in the CTE-5202 *ADVANCE* menu.

NOTE: If replacing a CTE-1103 thermostat as described in the Cooling Heating Changeover section of the [CEP-4000 Series Applications Guide](#) or a CTE-5001/5011 as described in its installation guide, the REE-1005 or REE-1014 relay module is not needed with the CTE-5202.

NOTE: Minimums can be set at zero air flow, but a minimum of greater than zero is required for a quick changeover.

NOTE: For an SSE-2001/2002 flow sensor, connect the X and Y terminals to the CTE-5202's AI1 and Common terminals.

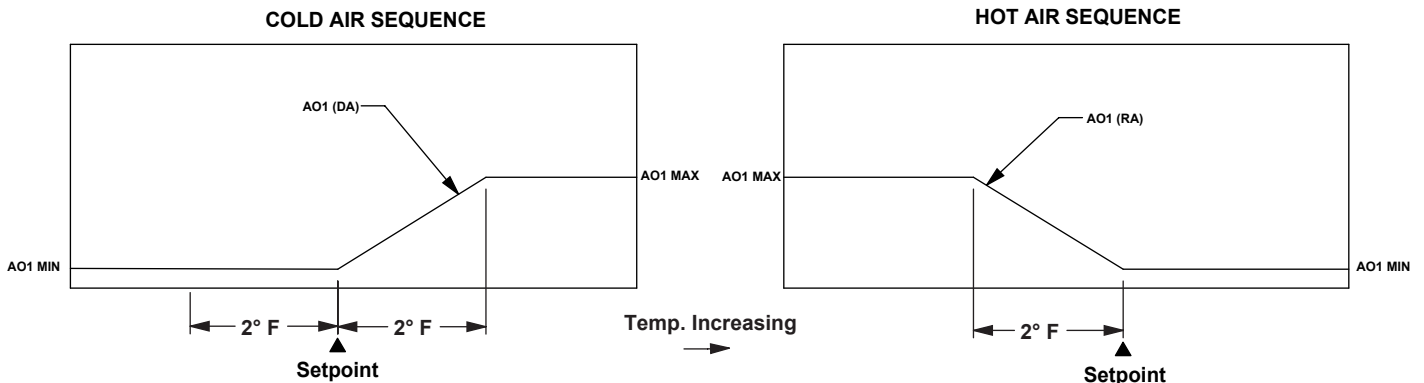
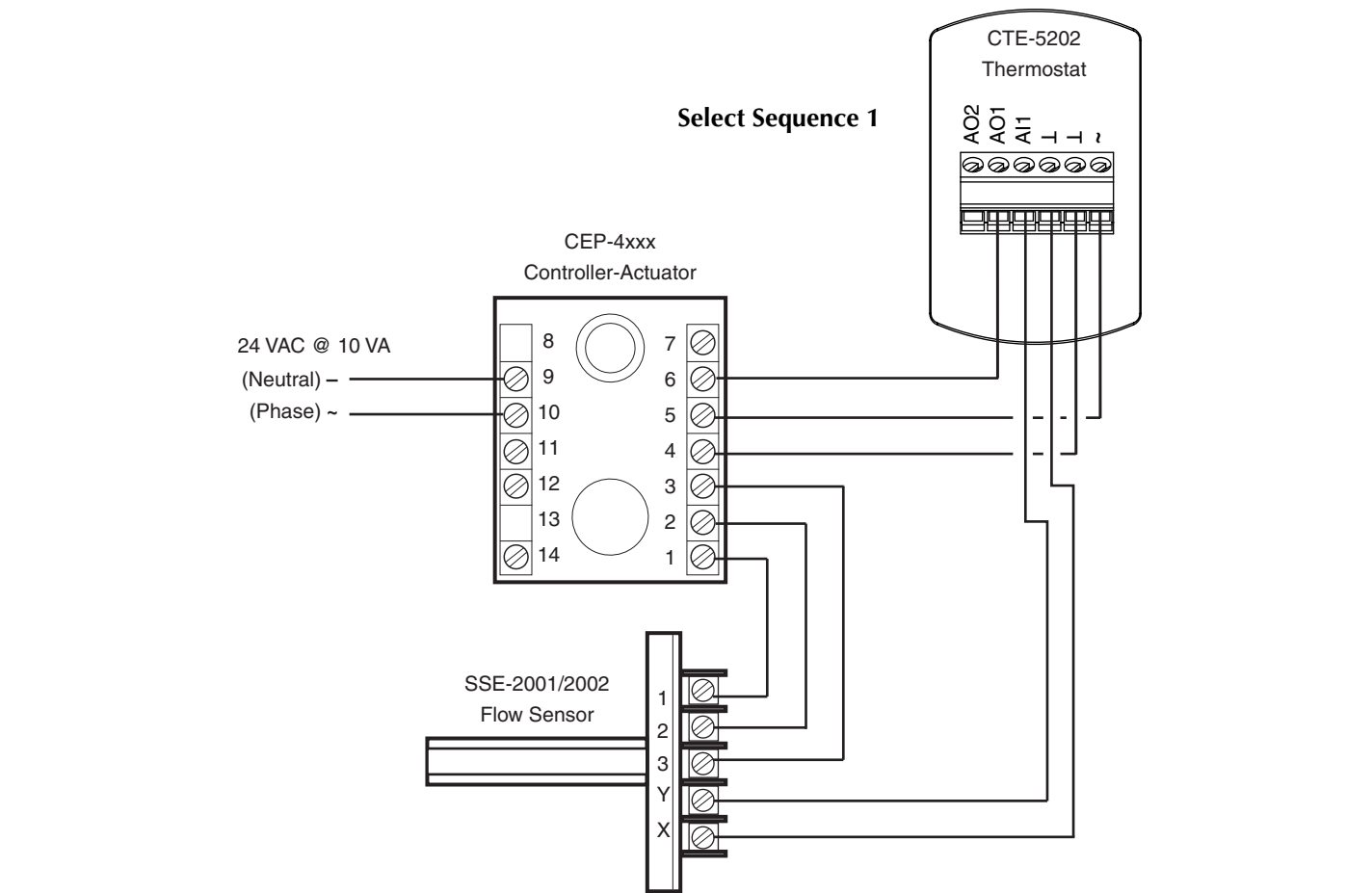

Cooling with Hot Water Reheat

See *Cooling with 3-Stage Reheat on page 48*. This application operates similarly except for using a hot water valve instead of electric heating elements for reheat.

AO1 controls airflow and AO2 controls the valve. When there is a call for heat, the thermostat modulates the hot water valve.

The CTE-5202 here replaces a CTE-1004 (DA cooling and RA heating) and is used in conjunction with an REE-4006 time proportioning relay module and a (NC) VEP-12/22/34 series hot water valve. The REE-4006 relay is designed for time proportioning control of thermic electrical hot water valves.

NOTE: The VEP-12/22/34 series valves and REE-4006 relay module have been discontinued. Replacement actuators (MEP-3001s) for those valves may still be available. The REE-4006 can be replaced by an REE-4106 or REE-5106, which have built-in power supplies that could be used to power the CTE-5202 if desired. See also use of a VEB-43/46 valve in *Cooling with Hot Water Reheat on page 41*.

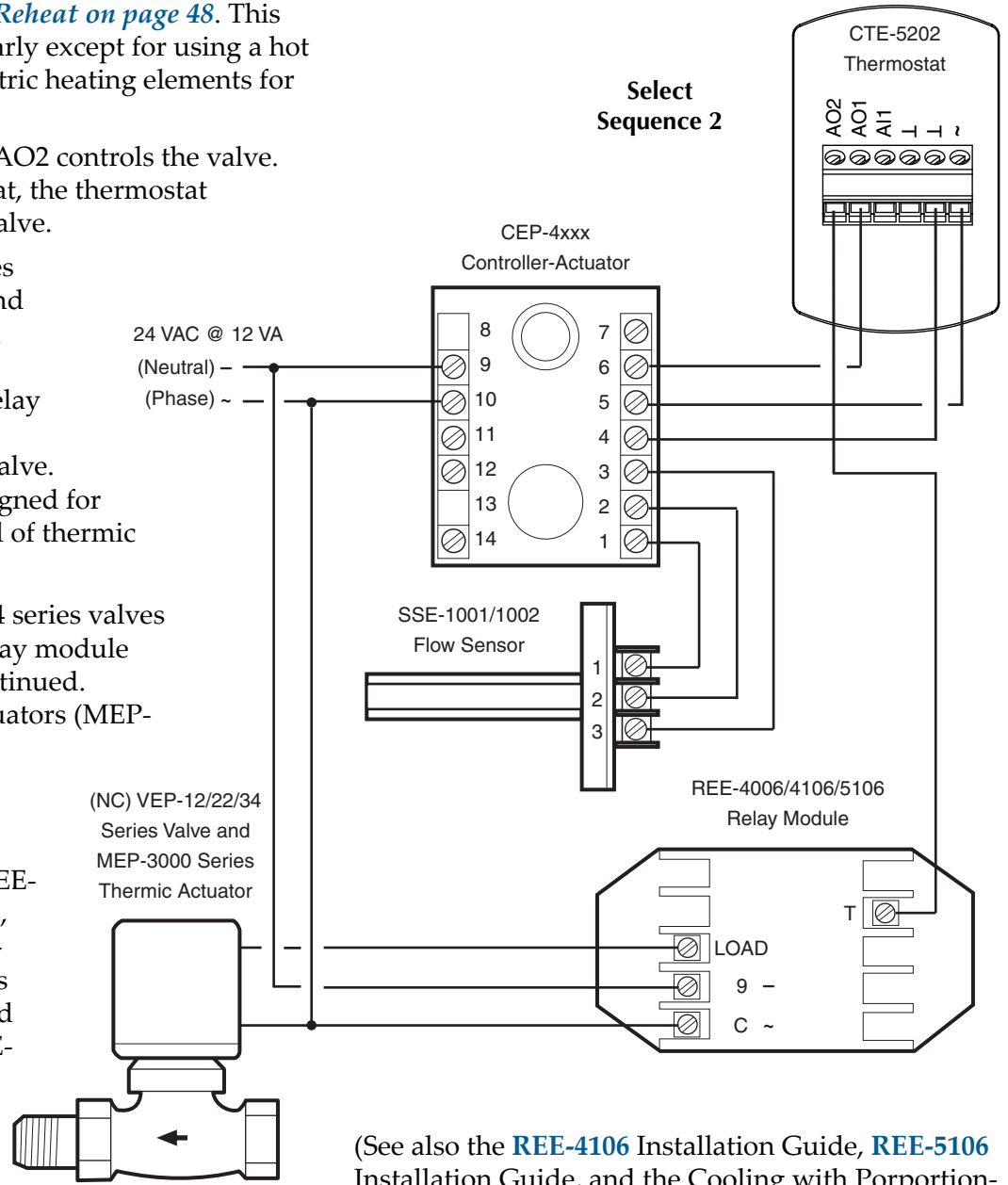

(See also the [REE-4106 Installation Guide](#), [REE-5106 Installation Guide](#), and the [Cooling with Porportional Reheat](#) section with a CTE-1004 in the [CEP-4000 Series Applications Guide](#).)

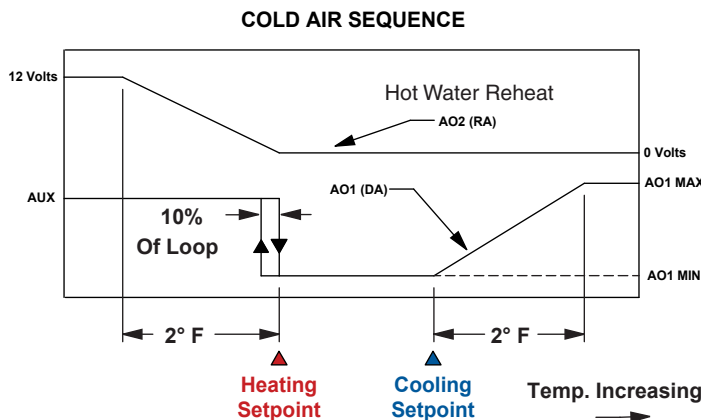

Fan Induction with 2-Stage Electric Heat

In this fan induction application, the CTE-5202 thermostat is used with a REE-4002/5002 relay module, a fan, and two coils (for two stages of heat). The REE-4002/5002 was designed primarily for use with VAV fan-powered induction boxes.

If the temperature drops below setpoint, the REE-4002/5002 senses the decrease in voltage on AO2 and starts the fan. As the temperature continues to drop, the first stage of reheat begins, and the second stage of reheat follows if the thermostat is still not satisfied. The process reverses as the room temperature begins to rise.

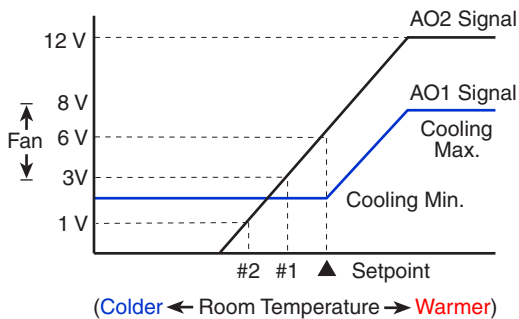

Sequence 1 should be selected from the CTE-5202 SYSTEM menu. See [Change Configuration on page 6](#).

(See also the Fan Box with Reheat section with a CTE-1101 in the [CEP-4000 Series Applications Guide](#).)

NOTE: The REE-4002/5002 provides the fan an adjustable start point. The "X" Terminal is used for measuring fan trip voltage. See the [REE-5002 Installation Guide](#) or the [REE-4002 Installation Guide](#) for details.

NOTE: Triac outputs on the REE-4002/5002 are for 24 VAC loads only. The phase side of the transformer connects to the "common" side of the load (contactors).

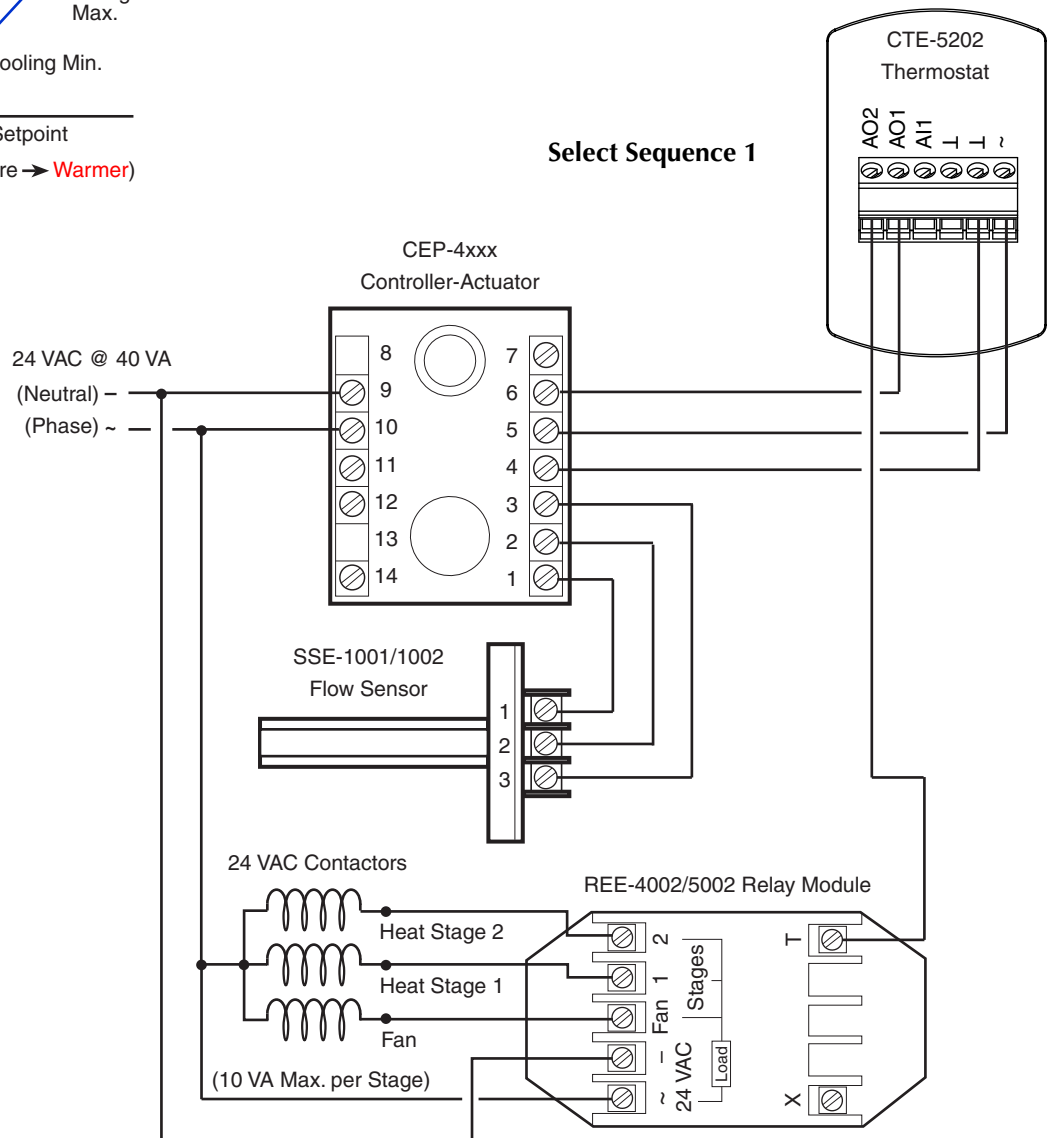

Damper Tracking (Master/Slave)

The configuration is used for special applications where a differential pressure is needed (either positive or negative). The thermostat controls the “master” CEP-4xxx controller-actuator and a (discontinued) REE-1013 relay controls the “slave.” The relay takes the voltage reading from the master CEP-4xxx and repeats it to the slave CEP-4xxx plus or minus a given offset.

As an example, the master CEP-4xxx is supplying a velocity of 450 fpm (4.0 VDC on terminal 6), and the relay commands the slave controller to exhaust 550 fpm (4.1 VDC). The amount of voltage “offset” would be 0.10 VDC to set-up the REE-1013. See the Voltage/Velocity Correlation section in the **CEP-4000 Series Applications Guide**. With the REE-1013, the maximum offset is ± 2 VDC as measured by a voltmeter between the + and - terminals.)

Select Sequence 1 (from the CTE-5202 *S Y S T E M* menu). See *Change Configuration on page 6*. (This replaces a CTE-1101 with Direct Acting reset.)

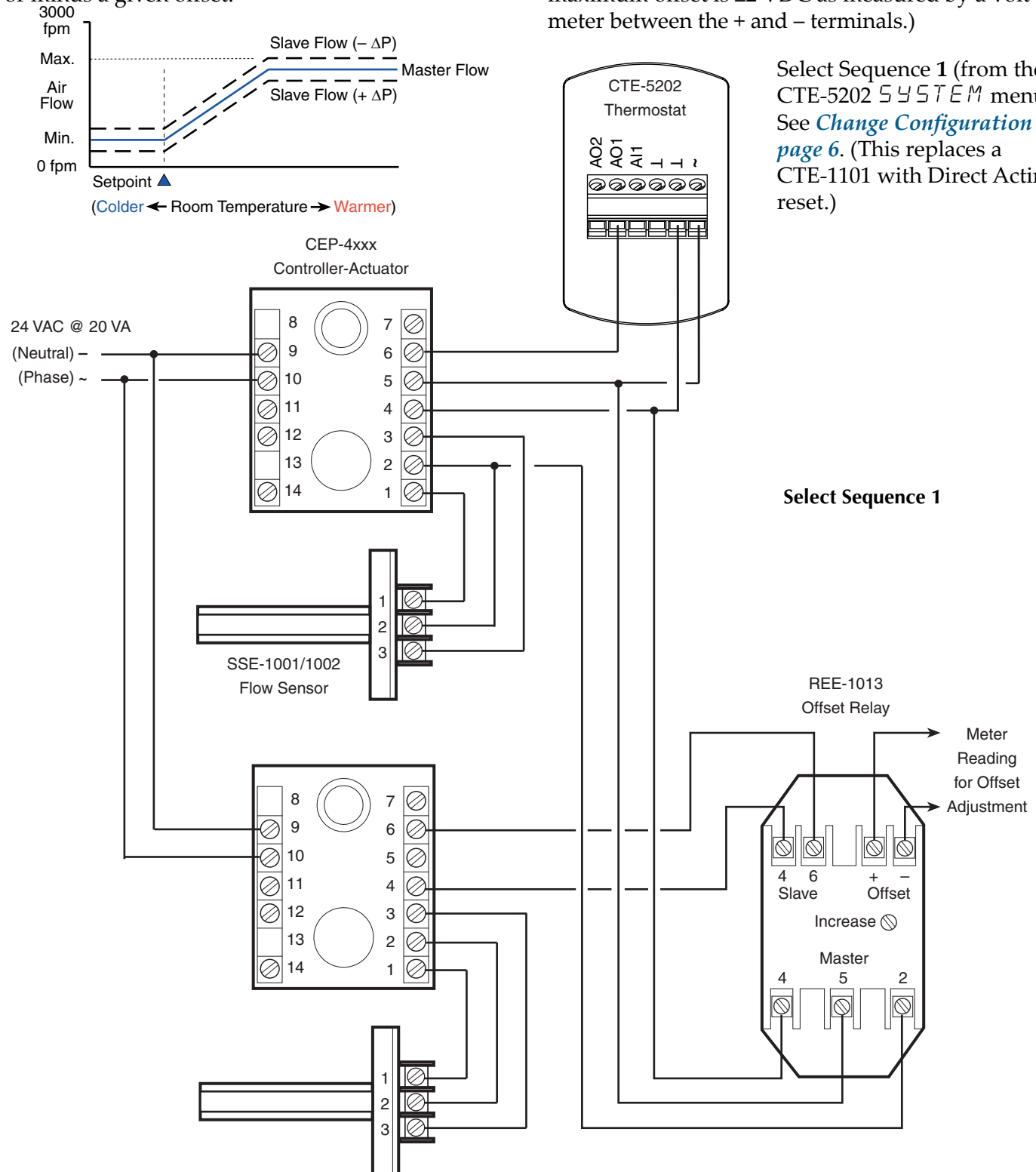

Dual Duct Heating and Cooling VAV

Dual duct applications connect two CEP-4000 series controllers, mounted separately on the hot and cold air-duct dampers, with each controller using its own flow sensor.

The hot deck controller receives its requested flow signal from AO2 on the CTE-5202, while the cold deck uses the AO1 signal. Both controllers can be set independently for minimum and maximum flow settings.

Sequence 3 should be selected from the CTE-5202 SYSTEM menu. See [Change Configuration on page 6](#).

(See also the (Dual Duct) Heating and Cooling VAV section with a CTE-1103 in the [CEP-4000 Series Applications Guide](#).)

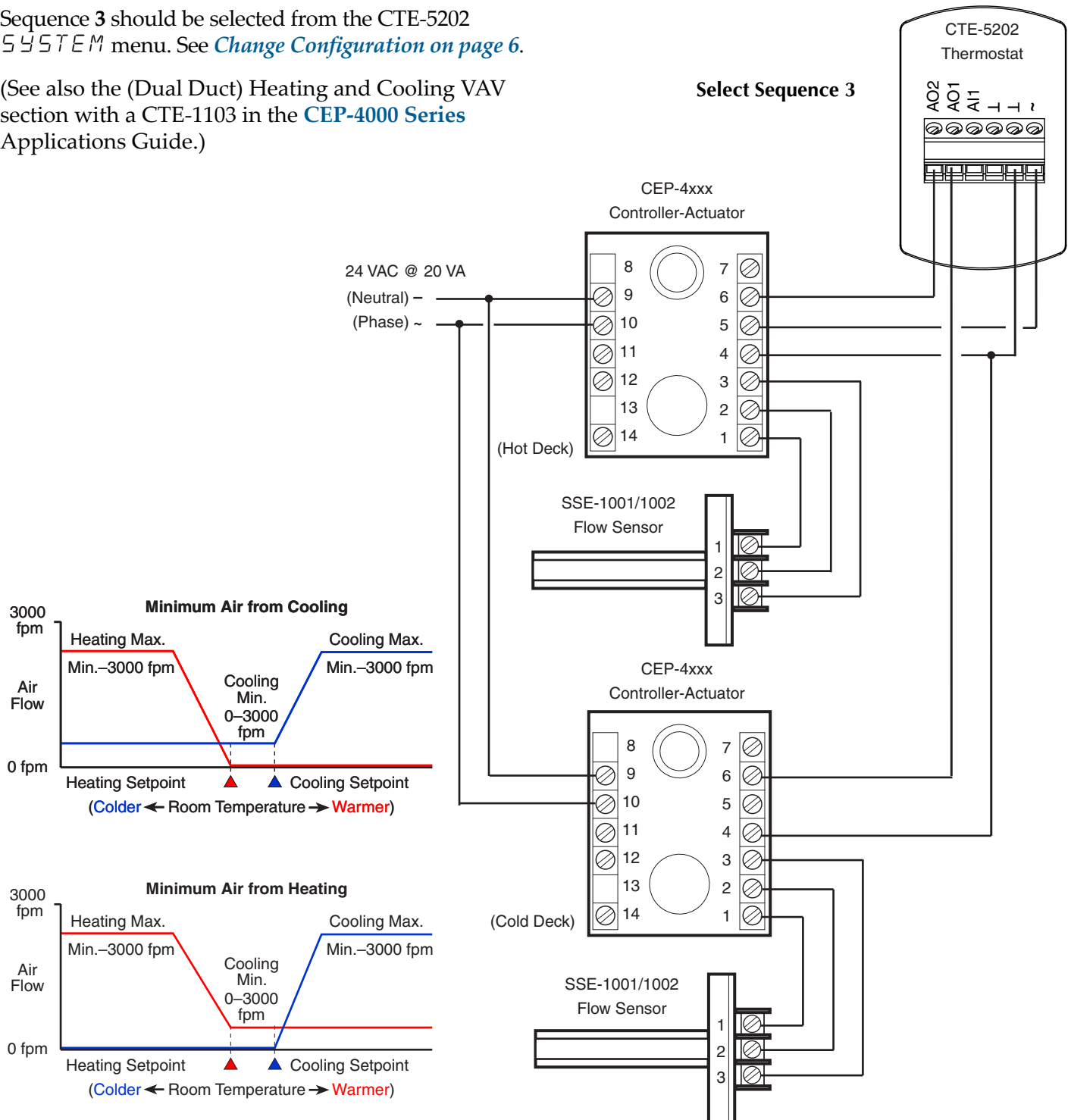

Dual Duct Heat/Cool Constant Volume with Hot Deck Make-Up

This application is designed for dual-duct installations requiring constant air volume (CAV). In this application, a single-duct cooling controller is mounted on the cold air duct, and its minimum and maximum flow is reset by the room thermostat. A second "slave" controller is mounted on the hot air duct as a constant volume unit, with the flow sensor measuring downstream "total flow" into the space. (The "slave" controller has no reset from the thermostat.)

As the cold deck resets from maximum to minimum flow, the hot deck controller senses a decrease in "total flow" to the space, opens the hot air duct to compensate, and thus maintains a constant combined airflow into the room.

Sequence 3 should be selected from the CTE-5202 *SYSTEM* menu. See [Change Configuration on page 6](#).

(See also the Dual Heating/Cooling Constant Volume w/ Hot Deck Make-Up section with a CTE-1103 in the [CEP-4000 Series Applications Guide](#).)

NOTE: Minimum and maximum to be set on the cooling side (AO1) in the CTE-5202 *LIMITS* menu. (Heating side makes up the remainder for the constant volume.)

Constant volume setting must be equal to or greater than cooling maximum.

Set constant volume on the heating side by adjusting maximum for AO2 to 10 VDC and adjusting AO2 minimum (volts) for the desired constant volume. (See the Voltage/Velocity Correlation chart in the [CEP-4000 Series Applications Guide](#).)

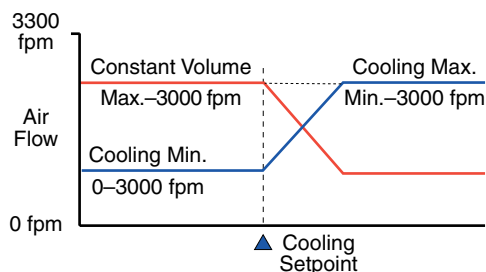

Select Sequence 3

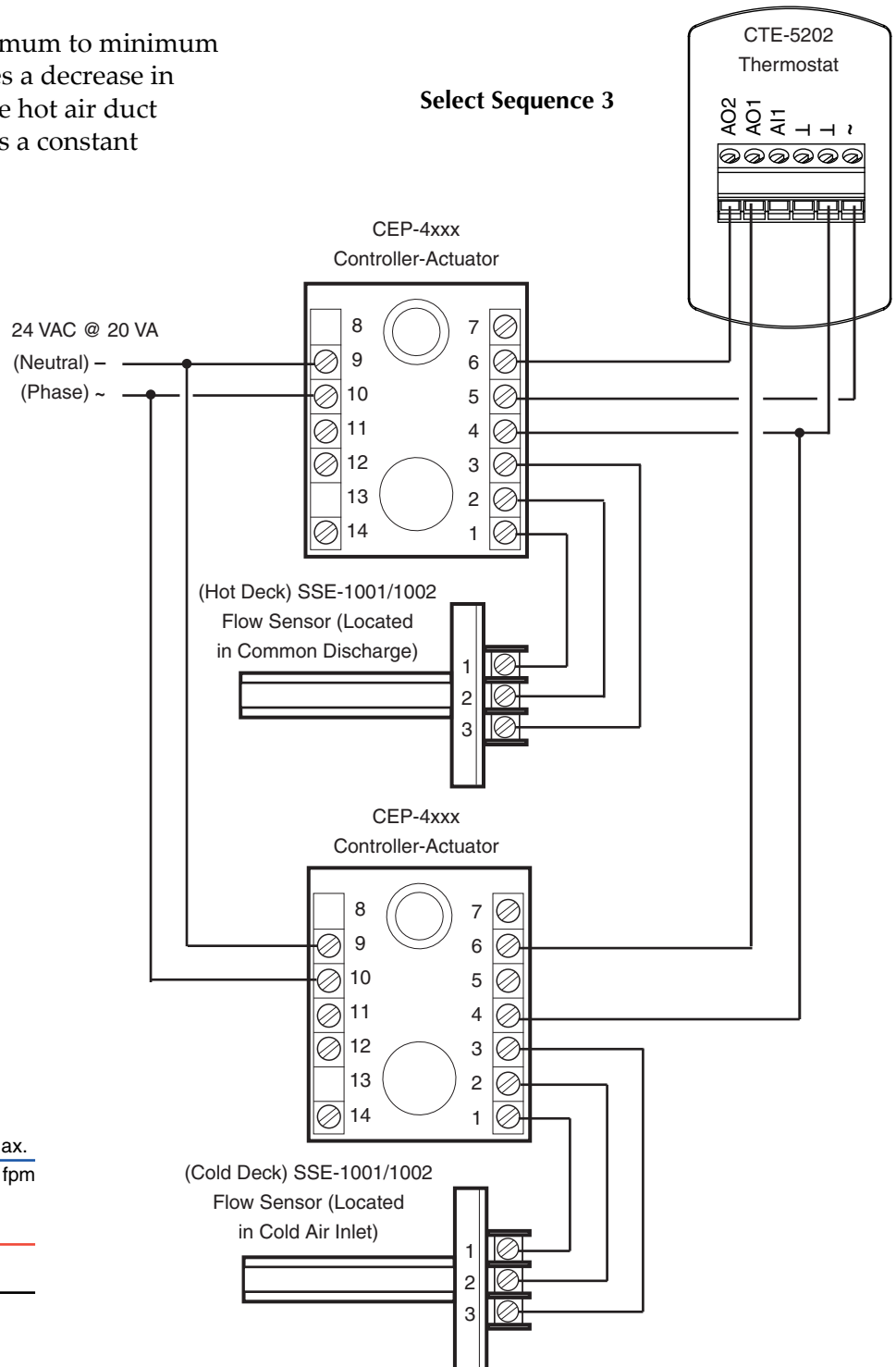

Barber Colman TP-81xx Thermostats

Replacement Applications

This section gives sample applications for using the CTE-5202 in the place of a Barber Colman (TAC, Invensys, Schneider Electric) TP-81xx thermostat. Some of the applications include use with MP-52xx “beer can” actuators.

TP-8101, TP-8102, and TP-8103 Leads and Terminals	Function	CTE-5202 Terminals
Red Wire Lead	+20 VDC	~ (Phase)
Yellow Wire Lead	Proportional Output	AO1
Blue Wire Lead	Common	⊥ (Common)
Terminal 1	Common	⊥ (Common)
Terminal 2	Auxiliary Input	AI1
NOTE: Use Sequence 1 . See sample applications on page 56 and page 57 .		

TP-8124 and TP-8125 Terminals	Function	CTE-5202 Terminals
OP2	2–15 VDC Cooling (DA)	AO1
+20	+20 VDC (Input)	~ (Phase)
OP1	15–2 VDC Heating (RA)	AO2
Com	Common	⊥ (Common)
NOTE: Use Sequence 3 . See sample applications on page 58 and page 59 .		



NOTE: The CTE-5202 may not work in all applications as a substitute for a TP-81xx. See the CTE-5202 Data Sheet and [Connection and Configuration on page 5](#) for additional details.

TP-8101/8102/8103 Replacement (General)

CTE-5202 thermostats can replace TP-8101/8102/8103 thermostats and use the 20 VDC supplied by a controlled device. (For more information, see the manufacturer's installation guide for the controlled devices.)

⚠ CAUTION

Never connect together the red leads (or +20 VDC terminals) of controlled devices with internal power supplies (with the exception of MP-52xx actuators—see [TP-8101/8102/8103 Replacement with MP-52xx Actuators on page 57](#)).

For **cooling**, select Sequence 1 (from the CTE-5202 *SYSTEM* menu). See [Change Configuration on page 6](#).

For **heating**, connect a 5K to 10K ohm resistor between Common and AI1. Select Sequence 1 and lower the Changeover to the lowest setting (55° F). See [Change Configuration on page 6](#). The resistor simulates a changeover sensor and puts the thermostat in Reverse Acting mode.

NOTE: If the resistor value is too high, the thermostat will not go into RA mode. If the resistor value is too low, the thermostat may go into setback mode.

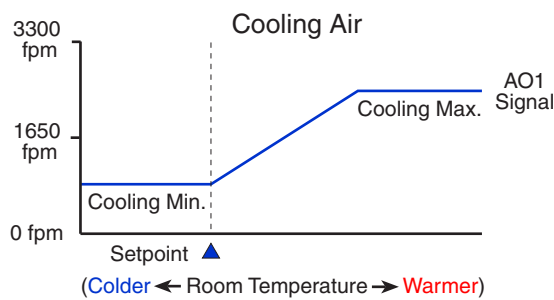
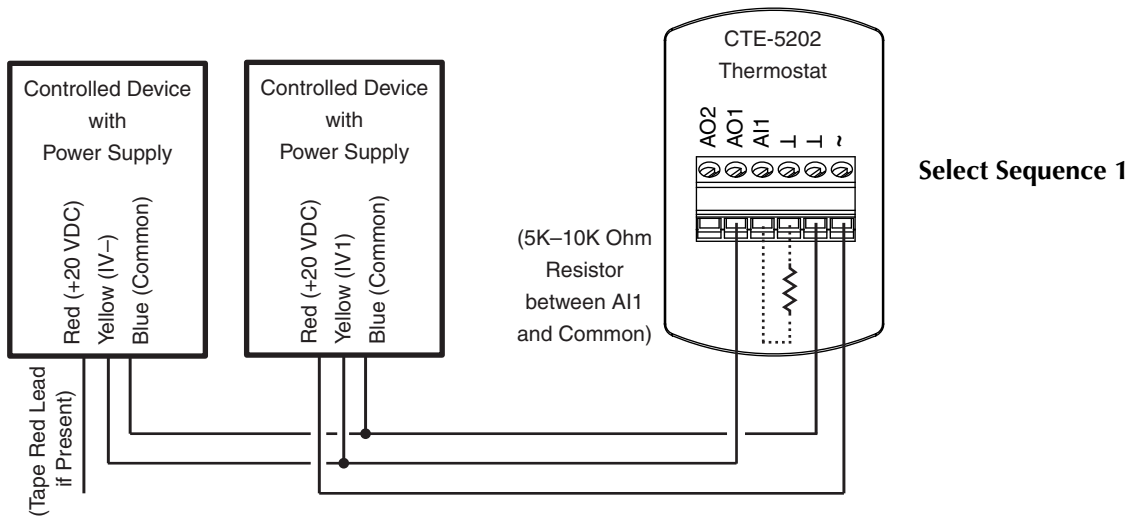

Select Sequence 1

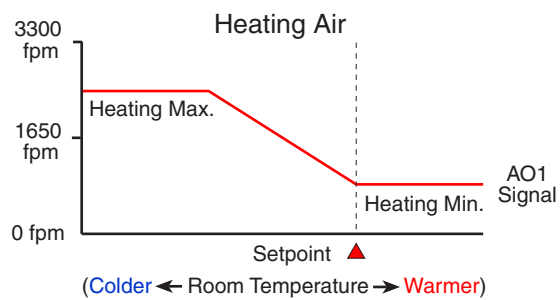

Select Sequence 1
AND set Changeover to 55° F

TP-8101/8102/8103 Replacement with MP-52xx Actuators

See [TP-8101/8102/8103 Replacement \(General\)](#) on [page 56](#). This is the same configuration except for the addition of MEP-52xx actuators and changes to the connections to the red leads.

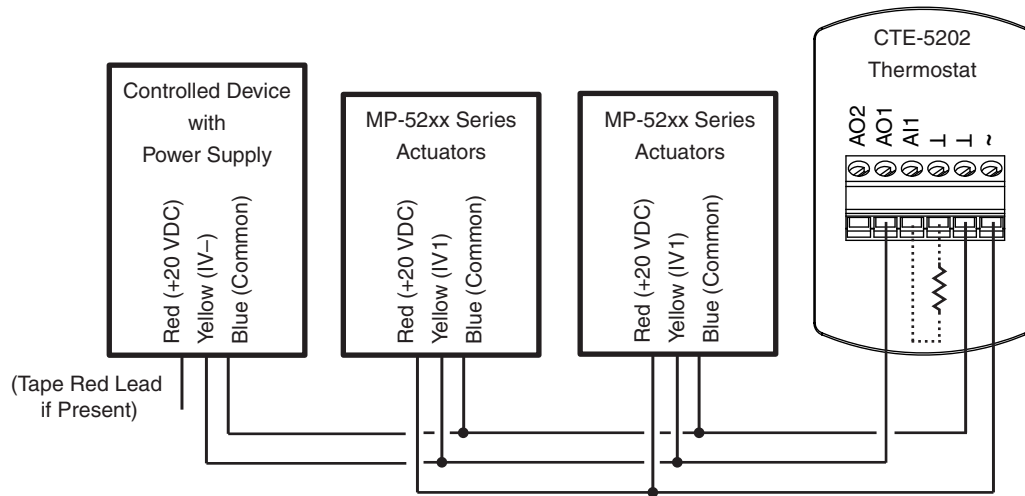

TP-8124/8125 Replacement with One or No MP-52xx Actuators

CTE-5202 thermostats can replace TP-8101/8102/8103 thermostats and use the 20 VDC supplied by a controlled device. (For more information, see the manufacturer's installation guide for the controlled devices.)

Select Sequence 3 (from the CTE-5202 *S Y S T E M* menu). See [Change Configuration on page 6](#).

⚠ CAUTION

Never connect together the red leads (or +20 VDC terminals) of controlled devices with internal power supplies (with the exception of MP-52xx actuators).

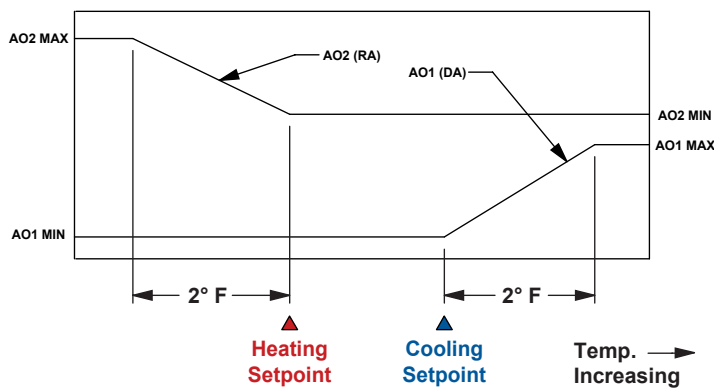
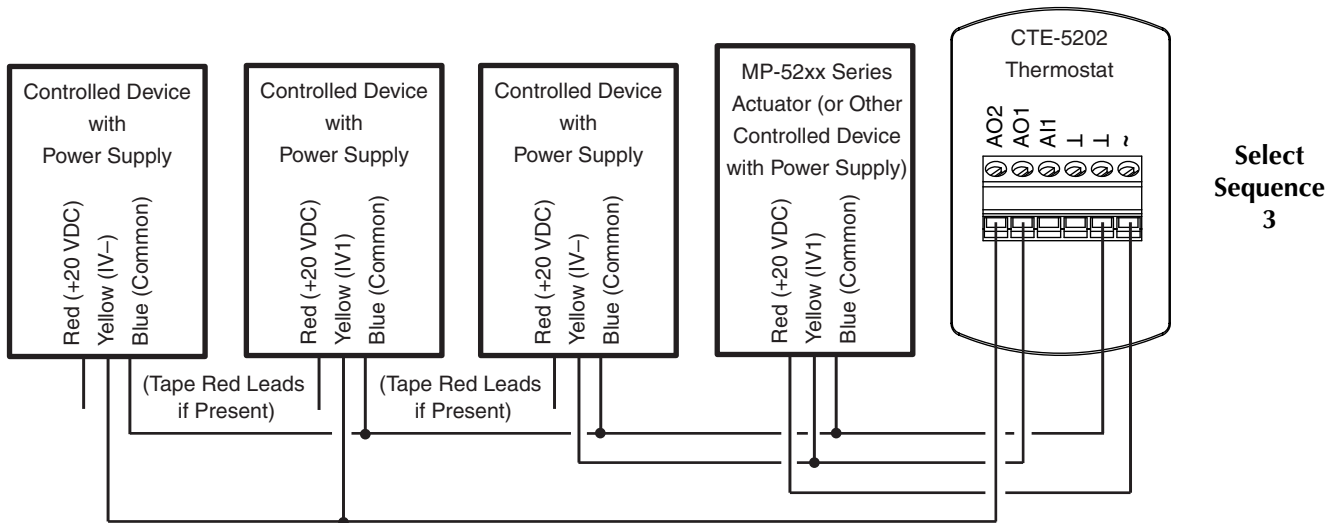

TP-8124/8125 Replacement with Two MP-52xx Actuators

See [TP-8124/8125 Replacement with One or No MP-52xx Actuators on page 58](#). This is the same configuration except for having two MEP-52xx actuators and changes to the connections to the red leads.

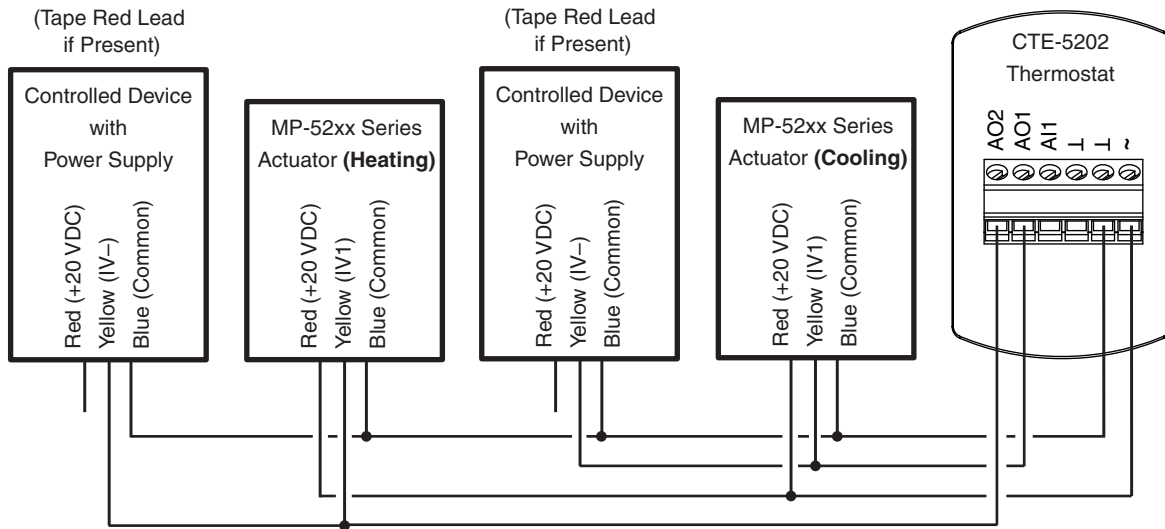

Index

Symbols

9.1 VDC vs. 24 VAC Power: [45](#)

A

Accessories: [4](#)

Actuator

MEP-4002: [17](#)

MP-52xx “Beer Can”: [55](#)

Advanced Features Menu: [6](#)

AI1, AO1, AO2: [5](#)

Auto and Override: [19, 24, 35](#)

B

Barber Colman TP-81xx: [55](#)

Baseboard: [12](#)

Blanking, Display: [6](#)

Bypass Control, Static Pressure: [20](#)

C

CAV (Constant Air Volume): [54](#)

CEP-4000 Series Controller-Actuators: [22, 44](#)

Changeover: [5, 16, 27, 28, 29, 38, 39, 40, 49](#)

Chilled Beam

2-Pipe Heating and Cooling with Changeover: [16](#)

4-Pipe Heating and Cooling: [15](#)

Cooling: [14](#)

Cold Deck: [53, 54](#)

Configuration: [6](#)

Constant Volume: [53, 54](#)

Cooling: [14, 18, 23, 34, 46](#)

Cooling or Heating: [18, 23, 34](#)

Cooling with 3-Stage Reheat: [25, 36, 48](#)

Cooling with 3-Stage Reheat and Night Setback/Setup:
[26, 37](#)

Cooling with Heating Changeover: [27, 38, 49](#)

Cooling with Heating Changeover and Electric Re-
heat: [28, 39](#)

Cooling with Heating Changeover and Hot Water
Reheat: [29, 40](#)

Cooling with Hot Water Reheat: [30, 41, 50](#)

Cooling with Morning Warm-Up: [47](#)

C or F Temperature Scale: [6](#)

Cross-Reference

Barber Colman TP-81xx: [8, 55](#)

KMC CTE-1x0x: [9](#)

KMC CTE-50xx: [8](#)

KMC CTE-510x: [10](#)

Other Thermostats: [8](#)

CSE-484x Controllers: [22](#)

CSP-4000 (CSP-40xx/42xx/44xx/46xx) Controller-
Actuators: [22, 44](#)

CSP-4702 Controller-Actuator: [20](#)

CSP-5001/5002 Controller-Actuators: [21, 33](#)

CTE-1x0x Cross-Reference: [9](#)

CTE-50xx Cross-Reference: [8](#)

CTE-510x Cross-Reference: [10](#)

CTE-1001 Replacement: [46](#)

CTE-1004 Replacement: [48, 50](#)

CTE-1101 Replacement: [46, 51, 52](#)

CTE-1103 Replacement: [49, 53, 54](#)

CTE-5001/5011 Replacement: [46, 49](#)

CTE-5002/5012 Replacement: [48](#)

CTE-5006/5016 Replacement: [25, 36](#)

CTE-5015 Replacement: [23, 34](#)

CTE-5101 Replacement: [10, 34, 35, 42](#)

CTE-5102 Replacement: [10, 34](#)

CTE-5103 Replacement: [10, 36, 38, 39, 40, 43](#)

CTE-5104 Replacement: [10, 36, 37, 41](#)

CTE-5105 Replacement: [10](#)

D

Damper Tracking (Master/Slave): [52](#)

Deadband: [6](#)

Differential: [6](#)

Display

Blanking: [11](#)

Troubleshooting: [11](#)

Dual Duct

Heat/Cool Constant Volume with Hot Deck Make-
Up: [54](#)

Heating and Cooling VAV: [53](#)

Minimum Air from Cold Duct: [32, 43](#)

F

Fan Induction with 2-Stage Electric Heat: [31, 42, 51](#)

Flow Sensors: [44](#)

F or C Temperature Scale: [6](#)

H

Heating and Cooling VAV: [53](#)

Heating/Cooling Constant Volume w/ Hot Deck Make-
Up: [54](#)

Heating, RA and DA: [13, 18, 23, 34](#)

Hot Deck: [53, 54](#)

I

Important Notices: [4](#)

Input: [5](#)

Integral: [6](#)

Invensys TP-81xx: [55](#)

L
Limits: **6, 24, 35**
Loop
 Integral Time: **6**
 Proportional Band: **6**

M
Master/Slave: **52**
MEP-4002 Actuator: **17**
Minimum Setpoint Differential: **6**
Morning Warm-Up: **5, 7, 28, 29, 39, 40, 47**
MP-52xx “Beer Can” Actuators: **55, 57, 58, 59**

O
Offset: **6**
Operation: **5**
Outputs: **5**
Override: **19, 24, 35**

P
PID Loop: **6**
Pressure Control, Static: **20**
Pressure Dependent VAV: **17**
Pressure Independent VAV: **20, 33, 44**
Proportional Band: **6**

R
RA and DA Heating: **13**
REE-1013 Relay Module, Offset: **52**
REE-4001 Relay Module, 3-Stage Reheat: **48**
REE-4002 Relay Module, Fan with 2-Stage Reheat: **51**
REE-4006 Relay Module, Proportional Reheat for NC Valves: **50**
REE-4106 Relay Module, Proportional Reheat for NC Valves: **50**
REE-5001 Relay Module, 3-Stage Reheat: **25, 26, 28, 36, 37, 39, 48**
REE-5002 Relay Module, Fan with 2-Stage Reheat: **31, 42, 51**
REE-5106 Relay Module, Proportional Reheat for NC Valves: **50**

S
Schneider Electric TP-81xx: **55**
Sequences: **6, 7**
Setback: **5, 26, 37**
Setpoint
 Adjusting: **6**
 Troubleshooting: **11**
Span: **6**
SSE-1001/1002 Flow Sensors: **46, 48, 50, 51, 52, 53, 54**
SSE-2001/2002 Flow/Temp. Sensors: **47, 49**
SSS-10xx Flow Sensors: **20**
Standby (Setback): **5**
Static Pressure Controller: **20**
STE-140x Duct Sensor: **38, 39, 40**
STE-1454/1455 Strap-On Temp. Sensor: **16**
Support Files: **3**
System Menu: **6**

T
TAC TP-81xx: **55**
Temperature
 Offset: **6**
 Scale (F or C): **6**
 Troubleshooting: **11**
Terminals: **10**
TP-81xx Thermostats Cross-Reference: **55**
TP-8101/8102/8103 Replacement: **56, 57**
TP-8124/8125 Replacement: **58, 59**
Troubleshooting: **11**
TTE-2001 Duct Sensor/Transmitter: **38, 39, 40**

U
Unoccupied: **5, 26, 37**

V
Valve: **13, 14, 15, 16, 29, 30, 40, 41, 50**
VAV (Variable Air Volume)
 Pressure Dependent: **17**
 Pressure Independent: **20, 33, 44**
VEB-43/46 Series Valves: **13, 14, 15, 16, 29, 30, 40, 41**
VEP-12/22/34 Series Valves: **50**

W
Warm-Up. See Morning Warm-Up
Web Site: **3**
Wiring: **11**

KMC Controls

19476 Industrial Drive

New Paris, IN 46553

574.831.5250; Fax 574.831.5252

www.kmcccontrols.com; info@kmcccontrols.com