

Description

These detectors are designed to sense and transmit CO (carbon monoxide) gas levels to any compatible electronic analog control or building automation system for the control of ventilation equipment in industrial and commercial applications. They are for use in any industrial or commercial indoor environment where accurate CO detection is required.

The detector uses an electrochemical sensor to monitor the carbon monoxide level and outputs a field-selectable 0–5 VDC, 0–10 VDC, or 4–20 mA signal. The sensing range is 0–500 ppm, adjustable 100–500 ppm via the on-board menu. A front panel LCD is standard to ensure easy setup and operation.

Other standard features include a backlight for the LCD, a front panel silence/test button, status indication, and an alarm buzzer. The test function may also be controlled remotely with a digital input signal.

Two adjustable relays are optional features (SAE-1112).

Features

- ◆ Electrochemical sensing element with range of up to 0–500 ppm with ± 5 ppm or $\pm 5\%$ accuracy
- ◆ Powered by either 24 ($\pm 10\%$) VAC or 24 ($\pm 20\%$) VDC source
- ◆ Field-selectable analog output signal
- ◆ Audible alarm
- ◆ Front-panel backlit LCD display, silence/test button, and status indicator
- ◆ Menu-driven configuration set-up and testing
- ◆ Optional on-board relays with field-adjustable setpoints (SAE-1112)

Models

SAE-1111	Space CO sensor (replaces older SAE-1101)
SAE-1112	Space CO sensor with two relays (replaces SAE-1102)



Specifications

Gas Detected	Carbon Monoxide (CO)
Sensing Element	Electrochemical
Range	0–500 ppm, adjustable 100–500 ppm
Sample Method	Diffusion, or flow-through sample tube for duct-mount
Accuracy	± 5 ppm or $\pm 5\%$ of reading (whichever is greater) @ 32 to 122° F (0 to 50° C)
Life Expectancy	5 to 7 years in air (all commercial CO sensors have a finite life and must be replaced periodically to ensure reliable operation in detecting conditions that are potentially hazardous to human health and safety)
Typical Coverage Area	7500 ft ² (700 m ²)
Operation Conditions	–4 to 122° F (–20 to 50° C), 15 to 90% RH, non-condensing
Stability	< 5% signal loss/year

Response Time	< 30 seconds typical
Power Supply	24 (±20%) VDC or 24 (±10%) VAC (non-isolated half-wave rectified)
Consumption	425 mA @ 24 VAC max, 220 mA @ 24VDC max (test mode)
Protection Circuitry	Reverse voltage and transient protected
Output Signal	4–20 mA (3-wire), 0–5 VDC, or 0–10 VDC
Output Drive Capability	550 ohm max. for current output, 10K ohm min. for voltage output
Warm-up Time	1 minute
LCD Display	Displays ppm and menu parameters,, 35 mm W x 15 mm H (1.4" x 0.6"), alphanumeric two-line eight-character with backlight
Status LED	Two color (red/green) on front panel
Alarm (Buzzer)	
Sound Level	93 db @ 30 cm (0.98 feet)
Optional Relay Outputs	
Configuration	Two form C contacts (NO and NC), 5 Amps @ 140 VAC, 5 Amps @ 30 VDC
Relay Setpoint	Programmable via menu
Hysteresis	Programmable via menu
Delay	Programmable via menu
Wiring Connections	Screw terminal block (14–22 AWG), top or bottom conduit entry 22.73 mm (0.875") hole
Enclosure Ratings	Grey polycarbonate, UL94 V0, IP65 (NEMA 4X) with security screw installed
Regulatory	Sensor is UL recognized component; CE compliant

Dimensions

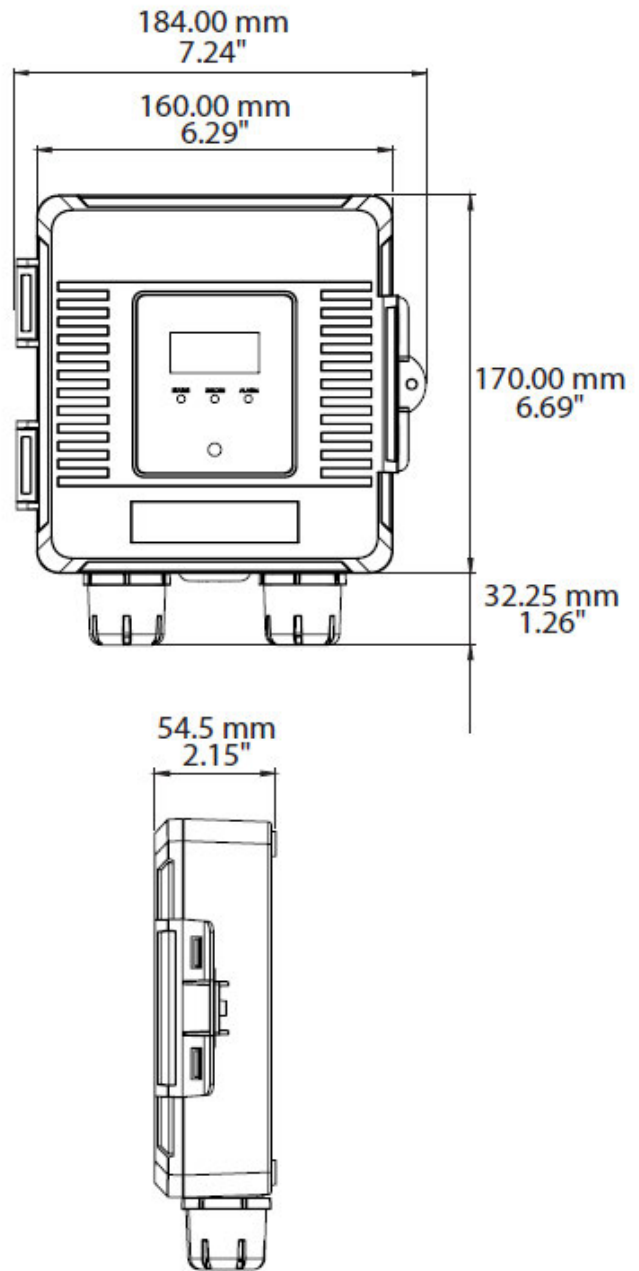

Accessories

XEE-6111-050	Transformer, 120-to-24 VAC, 50 VA, single-hub
XEE-6112-050	Transformer, 120-to-24 VAC, 50 VA, dual-hub

KMC Controls, Inc.

19476 Industrial Drive, New Paris, IN 46553

574.831.5250

www.kmcccontrols.com; info@kmcccontrols.com