

Installation Guide

These are brief instructions for installing a BAC-7000 series VAV controller. For more detailed instructions, review the document *Installation, Operation, and Application Guide for BAC-7000 Series VAV Controllers*.



www.kmccontrols.com/ag/bac-7003

Mounting

Refer to “Illustration 1—Mounting the BAC-7000 VAV controllers” when mounting the controllers on a VAV terminal unit.

Set the rotation limits

Before mounting the controller, set the rotational limits with the two supplied stop pins. These settings limit the shaft rotation in the clockwise (CW) and counterclockwise (CCW) directions.

Mount the controller

1. Back the set screws out of the drive hub until the shaft can fit through the collar.
2. Place the controller on the damper shaft in the approximate final position.
3. Position the anti-rotation bracket and fasten it using #8 or #10 self-tapping screws. Verify the notch in the bracket securely engages the lock tab on the controller.
4. Manually position the VAV damper in the fully open position.
5. Press the gear clutch button and rotate the drive hub in the same direction that opened the damper. Turn the hub until it reaches a rotation limit.
6. Tighten the two set screws in the drive hub to approximately 50–inch pounds (5.65 N•m) to lock the hub to the shaft.



Illustration 1—Mounting the BAC-7000 VAV controllers

Wiring

All input, output, power and network connection points are located beneath the access cover. Remove the two screws that secure this cover to remove the cover.

The controller is supplied with a removable conduit plate with two 0.5 inch threaded conduit couplings. If conduit connections are used, note the following:

- ◆ The conduit plate may be removed by removing the two screws that secure the access cover and removing the cover. Connect the required conduit and replace the plate in the controller housing.
- ◆ The plugs may also be sliced to allow wiring to enter the controller with a minimum of outside contaminates.

Connecting inputs

The BAC-7000 VAV controllers have three universal inputs. Each input is configured to support the standard application programs in the controller. By using the internal termination resistors, either passive or active devices may be connected to the inputs.

Note: If a NetSensor is connected to the controller, the standard application programming will use the temperature and setpoint from the NetSensor and not from devices connected to Input I1 and Input I2.

KMC supplied Control Basic programs assigns inputs to the following functions.

Input I1—Connect to a space temperature sensor input such as the 10 kΩ thermistor in an STE-6000 series sensor.

Input I2—This is a setpoint input which is typically the 0-10 kΩ potentiometer STE-6000 series sensor.

Input I3—This is an optional input configured for a 10 kΩ. discharge air temperature sensor.

Setting the internal pull-up resistors—For passive input signals, such as thermistors or switch contacts, set the input termination switch to the On position.

Ground terminals—Use the GND terminal located next to the input terminals for the input ground connection.

Connecting outputs

The BAC-7003 and BAC-7053 include one single-stage triac, one relay and one universal output.

When connecting loads to the triac or relay output, use only the terminal marked RTN associated with the triac or relay for the 24-volt circuit.

Output O1—This output is a universal output that can be programmed as either an analog object for modulating reheat. The universal output is rated for 0-10 volt DC loads. Use the GND terminal on the input connector block for the ground.

Output T2—This is a triac output programmed to switch 24-volt reheat circuits. The output is rated for 24 volt, 1 ampere loads, and switches on zero crossing. Use the RTN2 terminal for the T2 load.

Output R3—This is a normally open relay contact programmed to control a 24-volt fan starting circuit. The relay contacts are rated for 24-volts at 2 amperes. Use RTN3 for the R3 load.

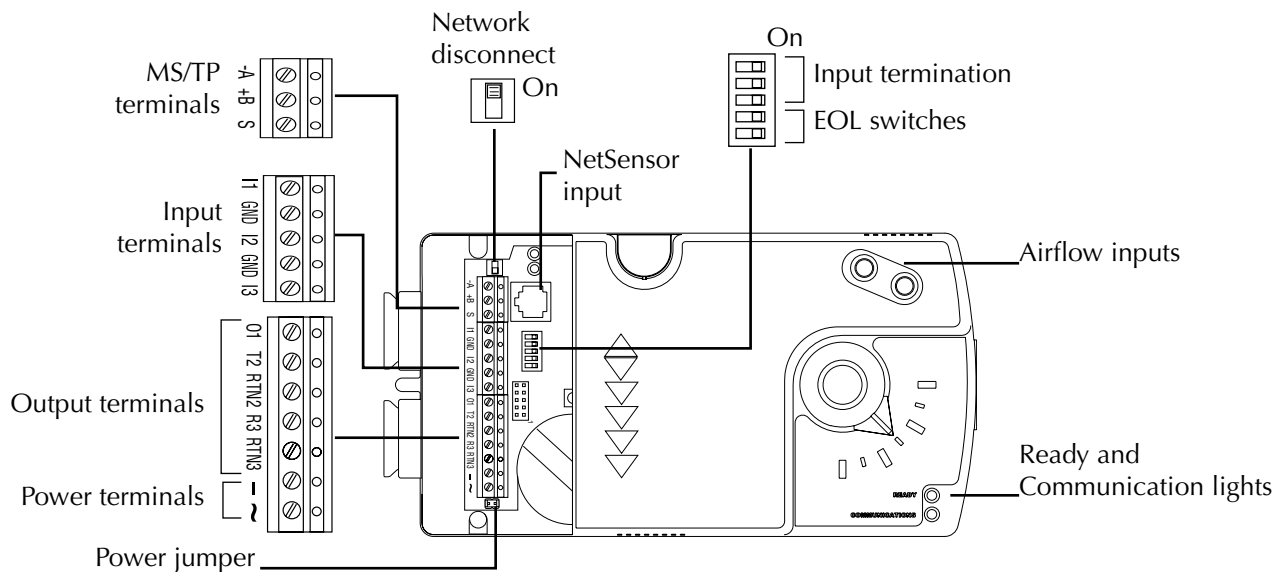

Illustration 2—BAC-7000 VAV controller with access cover removed

Connecting to a NetSensor

The Network RJ-12 connector provides a connection port to a NetSensor model KMD-1161. Link the controller to a NetSensor with a KMC Controls approved cable up to 75 feet long. See the installation guide supplied with the NetSensor for complete NetSensor installation instructions.

Connecting an airflow sensor

An airflow sensor is incorporated as one of the inputs to the controller. Remove the plugs and connect the tubing from the pitot assembly to the airflow sensor inputs above the drive hub.

Mount the controller close enough to the pitot tubes to keep the tubing length to be less than 24 inches between the controller's inputs and the tubes.

Connecting to an MS/TP network

BAC-7000 series VAV controllers BACnet MS/TP compliant controllers. Connect them only to a BACnet MS/TP network. Use the following principles when connecting a controller to an MS/TP network:

- ◆ Connect no more than 128 addressable BACnet devices to one MS/TP network. The devices can be any mix of controllers or routers.
- ◆ To prevent network traffic bottlenecks, limit the MS/TP network size to 60 controllers.
- ◆ Use 18 gauge, twisted pair, shielded cable with capacitance of no more than 50 picofarads per foot for all network wiring. Belden cable model #82760 meets the cable requirements.
- ◆ Connect the -A terminal in parallel with all other - terminals.
- ◆ Connect the +B terminal in parallel with all other

+ terminals.

- ◆ Connect the shields of the cable together at each controller. For KMC BACnet controllers use the S terminal.
- ◆ Connect the shield to an earth ground at one end only.
- ◆ Connect a KMD-5575 BACnet MS/TP repeater between every 32 MS/TP devices or if the cable length will exceed 4000 feet (1220 meters). Use no more than four repeaters per MS/TP network.
- ◆ Place a KMD-5567 surge suppressor in the cable where it exits from a building.
- ◆ On the controllers at the physical ends of the EIA-485 wiring segment, set the end-of-line termination to On using the EOL switches.

See *Application Note AN0404A, Planning BACnet Networks* for additional information about installing controllers.

Connecting power

The controllers require an external, 24 volt, AC power source. Use the following guidelines when choosing and wiring transformers.

- ◆ Use a KMC Controls Class-2 transformer of the appropriate size to supply power to the controllers.
- ◆ KMC Controls recommends powering only one controller from each transformer.
- ◆ Do not run 24 volt, AC power from within an enclosure to external controllers.

Connect the 24 volt AC power supply to the power terminal block on the lower right side of the controller near the power jumper. Connect the ground side of the transformer to the - terminal and the AC phase to the ~ (phase) terminal. Power is applied to the controller when the transformer is connected to power and the power jumper is in place.

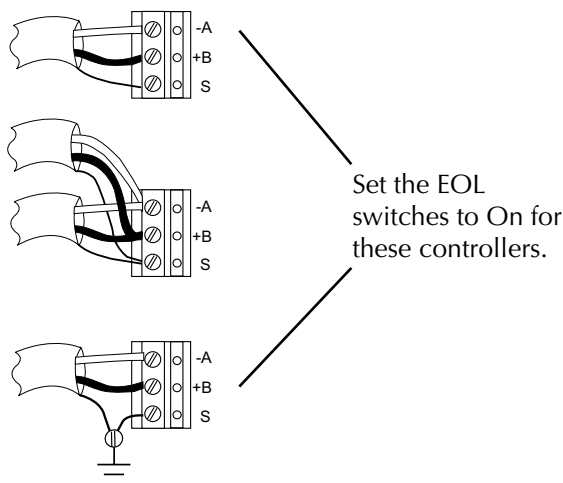

Illustration 3—MS/TP network wiring

Operation

Once configured, programmed and powered, the controller requires very little user intervention.

Configuration and set up

The BAC-7000 series VAV controllers are supplied with standard applications for single duct VAV terminal units. Final setup requires BACstage, TotalControl or another BTL listed BACnet Operator Workstation. Custom programming requires BACstage or TotalControl.

Balancing with a NetSensor

The BAC-7000 series VAV controllers include internal programming to use a KMD-1161 NetSensor as a technicians balancing tool. This procedure is described in the the document *Installation, Operation, and Application Guide for BAC-7000 Series VAV Controllers*.

Maintenance

BAC-7000 series VAV controllers require no routine maintenance. If necessary, clean with a damp cloth and mild soap.

Accessories and replacement parts

Replacement parts

HMO-4531	Non rotation bracket- KMD-7001
HPO-0054	Bulbs
HPO-0063	2-pin KMD jumper (5/Pkg)

Shaft adaptor

HFO-0011	3/8 inch (9.5 mm) shaft adaptor
----------	---------------------------------

Airflow sensors

Order one of the following for installation on VAV units without airflow sensor pickup tubes.

SSS-1012	3-5/32 in. length (80 mm)
SSS-1013	5-13/32 in. length (137 mm)
SSS-1014	7-21/32 in. length (195 mm)
SSS-1015	9-29/32 in. length (252 mm)

Power transformer

XEE-6111-40	Single-hub 120 volt transformer
XEE-6112-40	Dual-hub 120 volt transformer

Important Notices

The material in this document is for information purposes only. The contents and the product it describes are subject to change without notice. KMC Controls, Inc. makes no representations or warranties with respect to this document. In no event shall KMC Controls, Inc. be liable for any damages, direct or incidental, arising out of or related to the use of this document.

KMC Controls, Inc.
19476 Industrial Drive
New Paris, IN 46553
574.831.5250
www.kmcccontrols.com
info@kmcccontrols.com