

# Installation Guide

## Mounting

The CEP-4000 series are designed to mount on a standard 1/2 in. (13 mm) diameter shaft or (using the optional HFO-0011 adaptor) on a 3/8 in. (9.5 mm) shaft.

### Standard Instructions

1. Ensure that the damper can move freely through its entire range of motion. Fix any binding before installing the CEP-4000.
2. Slide the CEP-4000 directly onto the 1/2 in. diameter damper shaft. The shaft must extend a minimum of 1-3/4 in. from the mounting surface. (For a 3/8 in. shaft, see the HFO-0011 Adaptor section below.)
3. Place the non-rotation bracket (supplied) on the non-rotation tab.
4. Attach the non-rotation bracket to the mounting surface using (2) #8 or #10 self-tapping screws (not included).
5. Check that the standoffs (on the anti-rotation bracket) provide a 1/8-inch air gap behind the unit (see illustration).
6. Torque the two 5/16-18 setscrews to 75–85 in-lbs.
7. Mount the factory-calibrated, matching, SSE series sensor horizontally to maintain calibration at zero airflow.

### HFO-0011 Adaptor

1. Mount the CEP-4000 series actuator over the 3/8 in. shaft.
2. Slide the HFO-0011 over the shaft into the drive hub of the actuator.
3. Align the adaptor slots with the setscrews.
4. Partially tighten the setscrews.
5. Continue with step 2 under the Standard Instructions section above.

**NOTE:** See also the **CEP-4995 Universal Replacement** section on page 4 if installing that replacement model.

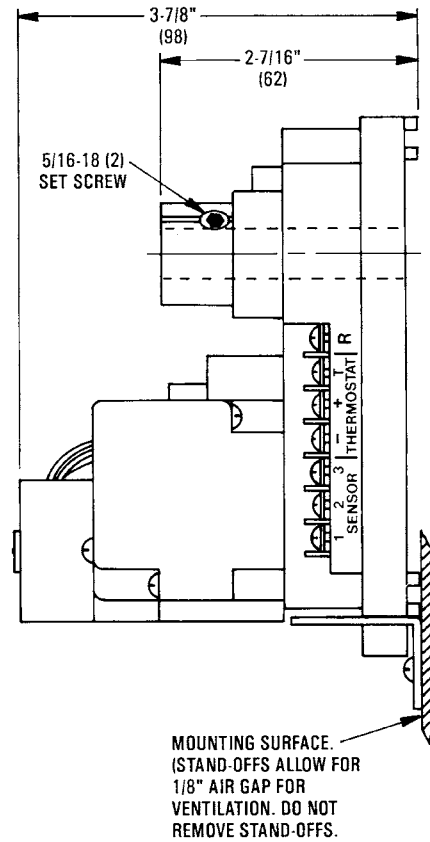

CEP-4000 Side View

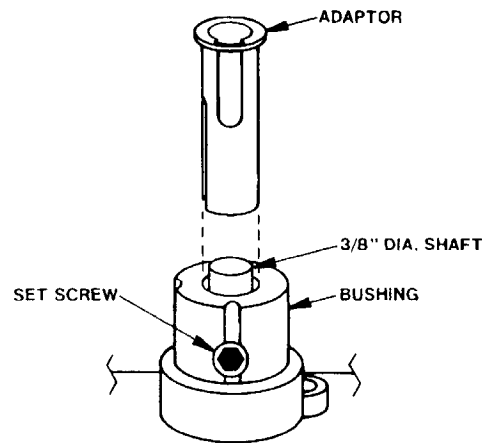

HFO-0011 Adaptor

**NOTE:** For information about connections and usage with newer CTE-5202 thermostats, see the [CTE-5202 Applications Guide](#).

# Wiring

1. Connect the CEP to an SSE sensor:
  - A. Terminal 1 to sensor terminal 1.
  - B. Terminal 2 to sensor terminal 2.
  - C. Terminal 3 to sensor terminal 3.
2. Connect the CEP to a CTE thermostat:
  - A. Terminal 4 to thermostat terminal “-”.
  - B. Terminal 5 to thermostat terminal “+”.
  - C. Terminal 6 to thermostat terminal “T1” for cooling (CTE-1001) or “T2” for heating air flow (CTE-1002).
3. Connect the CEP to a 24 VAC, -15%/+20%, 50/60 Hz power source (disconnect the power to the transformer while wiring the CEP):
  - A. Terminal 9 to the “-” common side of the transformer.
  - B. Terminal 10 to the “~” phase side of the transformer.
4. Optionally, the duct airflow can be read by measuring the voltage on:
  - A. Terminal 2 (+) and 4 (-) for 9 to 18 VDC = 0 to 3000 fpm.
  - B. Terminal 7 (+) and 4 (-) for 1 to 5 VDC = 0 to 3000 fpm.

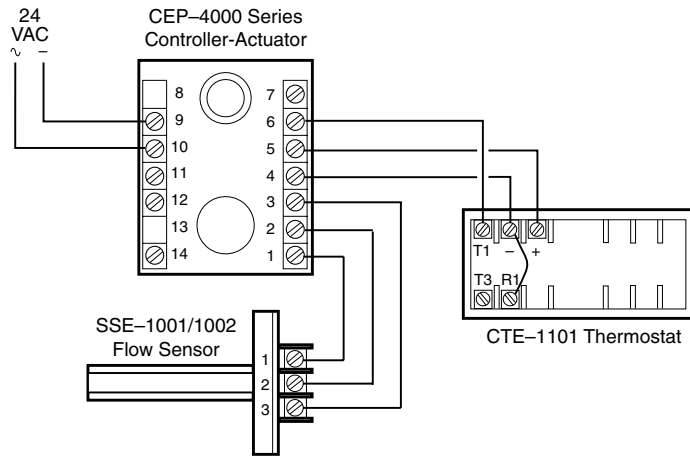

CEP-4000 Basic Connections

## ⚠ CAUTION

To prevent damage to the SSE series sensors, do not touch or handle the interior wire windings.

NOTE: If replacing a CEP-1000 or CEP-3000 series controller, the REE-1000 series relay may also need to be replaced with the equivalent REE-4000 series module. See the [CEP-4000 Series Application Guide](#) for more information.

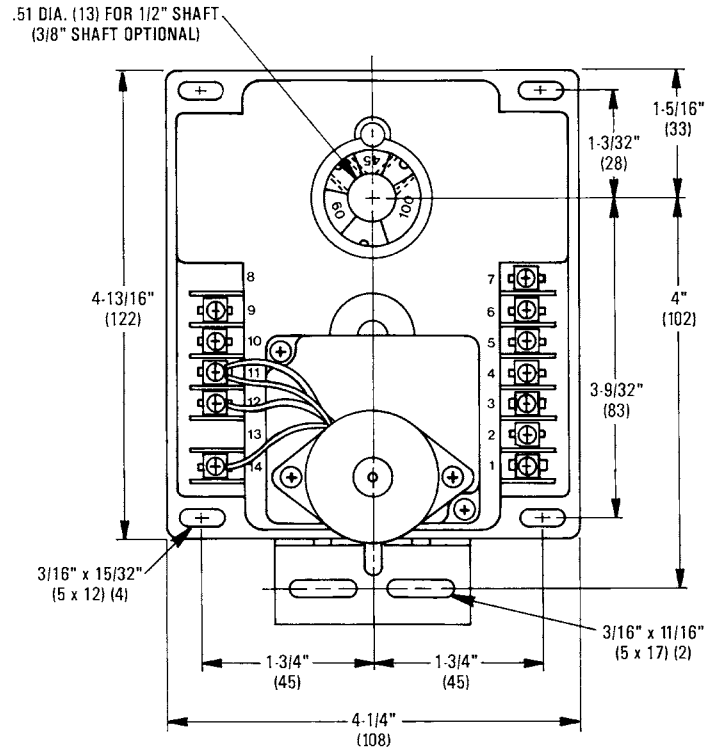

CEP-4000 Front View

## CEP-4000 Terminal Definitions:

1. Flow sensor terminal 1
2. Flow sensor terminal 2 (live flow reading with 9–18 VDC = 0–3000 fpm)\*
3. Flow sensor terminal 3
4. Thermostat (-) ground\*
5. Thermostat (+) 9.1 VDC\*
6. Requested flow from T1 or T2 thermostat (3–6 VDC = 0–3000 fpm)
7. Live flow sensor readout (1–5 VDC = 0–3000 fpm)
8. Unused
9. 24 VAC (-) common
10. 24 VAC (~) phase
11. Motor common
12. Motor drive to increase air velocity (open)\*†
13. Unused
14. Motor drive to decrease air velocity (close)\*†

## ⚠ CAUTION

\*Do not short terminals 12 and 14, 4 and 5, or 2 and 4.

†Do not apply voltage to terminals 12 or 14.

## Adjustments and Calibration

Each CEP-4000 is calibrated to its SSE series sensor at the factory. No further calibration is needed. If the units are replaced or become mismatched, complete the following steps to recalibrate the controller and sensor.

1. **Follow steps 1 and 3 under the Wiring section.**  
Connection of the thermostat is not necessary.
2. Connect the voltmeter "+" to CEP terminal 2 and "-" to CEP terminal 4.
3. Ensure zero airflow in the duct or remove the sensor from the duct and place it in a horizontal position with **zero** airflow.
4. Wait 5 minutes for the CEP and SSE units to stabilize.
5. Access the trimpot through the slot in the CEP-4000's side. The slot is normally covered by a label and is on the sensor/thermostat connection side (see illustration below).
6. Adjust the trimpot until the voltmeter reads 9 volts. When the adjustment is made, the voltage will immediately overshoot and then stabilize. This reestablishes the baseline. (See the CEP-4000 Airflow vs. Voltage chart.)
7. Wait an additional 5 minutes for the CEP and SSE units to stabilize.
8. Readjust if necessary.

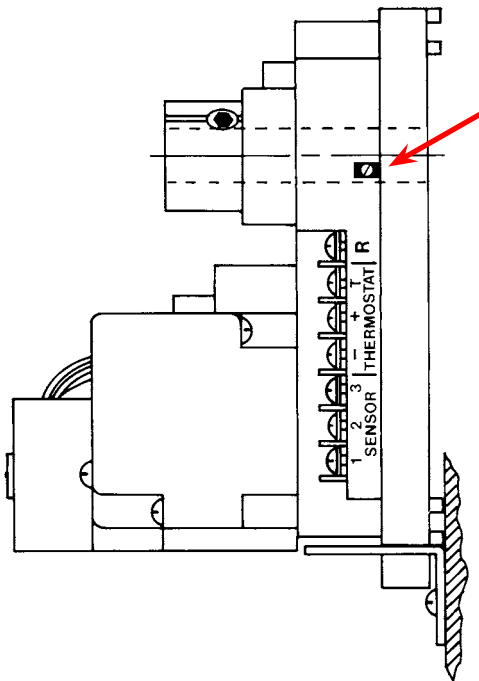

CEP-4000 Trim Potentiometer

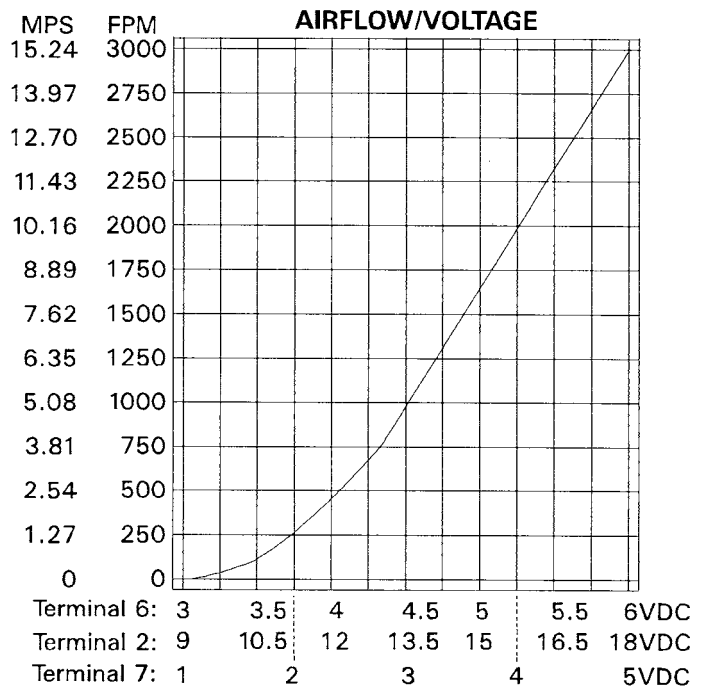

CEP-4000 Airflow vs. Voltage

## Rotation Setup and Override

If desired, the **rotation direction can be reversed** by swapping the red and blue motor wires according to the following table:

Rotation to Close	Motor Wire to Terminal 12	Motor Wire to Terminal 14
CCW	Red	Blue
CW	Blue	Red

NOTE: Motor wires must remain connected to terminal screws (11, 12, and 14) due to components beneath terminals.

To **manually drive** the controller/damper **open or closed** (with 24 VAC on terminals 9 and 10), remove the wiring to terminal 6, and temporarily jumper terminal 6 to:

- Terminal 5 (9.1 VDC) = Open
- Terminal 4 (- VDC) = Closed

NOTE: Full rotation may take five to six minutes because the actuator rotates at 18° per minute. A magnetic slip-clutch inside the actuator allows motor to continue running even when end-stops have been reached.

### ⚠ CAUTION

**Do not short terminals 12 and 14, 4 and 5, or 2 and 4.**

## CEP-4995 Universal Replacement

The CEP-4995 (100° rotation, CW to close, no sensor) is a “universal replacement” for most applications and will replace **MOST** CEP-1000/3000/4000 series controllers. The CEP-4995 is factory-wired to rotate clockwise (CW) to close and has internal stops that limit actuator rotation to 100 degrees. No sensor is included, and the unit must be calibrated with the existing sensor. **In addition to the instructions elsewhere in this document, note these additional instructions for this model.**

1. Before installing, verify that the terminal unit has damper stops in the closed position before replacing the controller/actuator.

**NOTE:** Most VAV terminal units with 45 or 60 degree rotation have damper stops as part of the damper blade design. Terminal units that rotate 90 degrees have stops integrated into the actuator and do not require damper stops. If stops do not exist in the closed position, the CEP-4995 will not work and a correct replacement unit must be ordered.

2. The majority of CEP controllers are used on CW to close VAV terminals. To convert a CEP-4995 to CCW to close, see the Rotation Setup and Override section.
3. Mounting the CEP in the open position is recommended practice. To manually cycle the unit into an open position, see the Rotation Setup and Override section.
4. If sensor resistance (measured between terminals 1 and 3) is between 100 and 400 ohms the sensor is operational. The CEP-4995 must still be calibrated to the sensor. See the Adjustments and Calibration section.
5. If the existing controller/actuator is a CEP-1000 or CEP-3000 series, determine if any relays are on the VAV terminal. REE-1001/1002/1006/1011/1015/1017/1019 relays must be replaced by their REE-4000 series equivalent (REE-4001/4002/4006/4011/4015/4017/4019).
6. For future reference of the original model number, use a permanent marker to cross out the “4995” part of the new unit’s model number and write in the model number of the old controller/actuator.

## Maintenance

No routine maintenance is required. The motors are permanently lubricated and all internal gear-train components are oil-impregnated. Careful installation will also ensure long term reliability and performance.

## More Information

For complete specifications and list of accessories, see the [CEP-4000 Series Data Sheet](#) on the KMC web site.

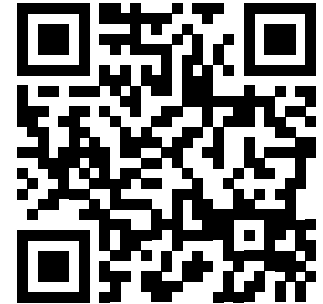

For principles of operation, troubleshooting, additional calibration procedures, and sample applications with the CTE-1000/1100/5000 Series series thermostats, see the [CEP-4000 Series Application Guide](#).



For information about connections and usage with newer CTE-5202 thermostats, see the [CTE-5202 Applications Guide](#).



**KMC Controls, Inc.**  
19476 Industrial Drive  
New Paris, IN 46553  
574.831.5250  
[www.kmcccontrols.com](http://www.kmcccontrols.com)  
[info@kmcccontrols.com](mailto:info@kmcccontrols.com)