



SAE-1162

Mounting

Choose a mounting location in a straight section of a return air duct. Mount at least 5 feet (or 7.5 duct diameters) from corners and other items that may cause disturbances in the air flow. Avoid areas prone to vibration or rapid temperature change.

1. Cut a 1-1/8 or 1-1/4 inch hole in the duct for the air sampling probe.
2. Insert the probe through the hole, align the unit so that the duct air flow is parallel with the side vent holes in the probe (air flows directly into the probe holes), and mark the four enclosure mounting holes.
3. Drill the four mounting holes (for screws) and remove any debris from all holes.
4. Insert the sampling probe into the duct.
5. Attach the unit to the ductwork by threading four screws through the four holes on the outside of the enclosure.
6. Remove the two cover screws (if installed), release the latch, and swing open the cover.
7. Insert wiring through a knockout. After wiring a duct sensor, fill the knockout hole with plumber's putty, caulk, or other sealant to prevent air infiltration from the conduit.
8. After wiring, configuring, and testing the unit (see later sections), close the cover and (optionally) secure it with two tapping screws.

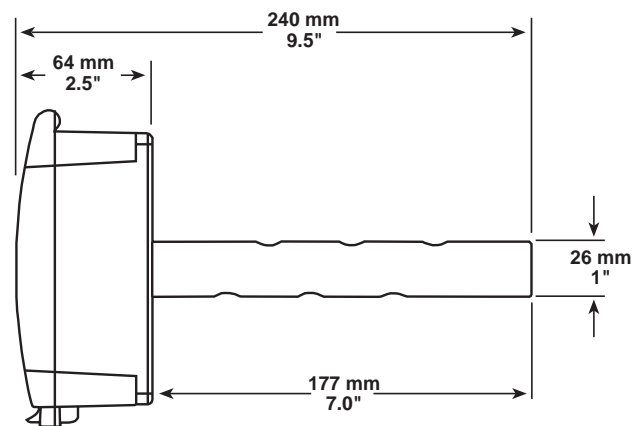
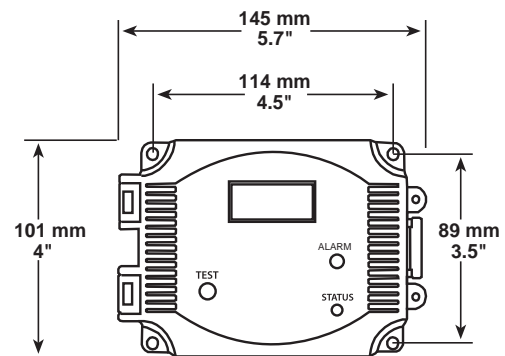

SAE-1162 dimensions

Wiring

Use 22 AWG shielded wiring for all connections. Do not locate device wires in the same conduit with wiring used to supply inductive loads.

1. Connect the positive DC voltage, or the hot side of the AC voltage, to the terminal marked **POWER** (but **do not apply power until all wiring is completed and Volt/mA position is selected**).
2. Connect the power supply common to the terminal marked **COM**. The device is reverse voltage protected and will not operate if connected backwards.

NOTE: The detectors have a half-wave power supply with the common the same as the output signal common. If several units are connected to one power supply, output signals share the same signal common. However, KMC recommends using a separate transformer for each device.

▲ CAUTION

Use caution when grounding the secondary of an AC transformer, or when wiring multiple devices, to ensure that the circuit ground point is the same on all devices and the controller. See Application Note AN0604D “Tips for connecting 24-volt power” available from the KMC Controls web site or in the SP-022 Digital Designer Guide.

3. Select the desired analog signal output switch position for either Current (4–20 mA) or Voltage (a menu item in the on-screen configuration selects 0–5 VDC or 0–10 VDC).

▲ CAUTION

The 4-20 mA current output signal operates in the active mode and does not require a loop power supply. The signal current is generated by the SAE-11xx detector and must not be connected to a powered input or device damage will result.

4. Set the input jumpers/pull-up resistors on the KMDigital or BACnet controller for the desired active voltage or current according to the controller’s instructions.
5. Connect the detector’s **OUT** terminal to the controller’s input (referenced to the COM terminal) according to the illustration.

NOTE: See also Application Note AN0504L “Connecting inputs and outputs to KMC controllers” available from the KMC Controls web site or in the SP-022 Digital Designer Guide.

NOTE: The sets of optional (form “C”) **relays** feature Normally Open (NO), Normally Closed (NC), and Common (COM) terminals. The relay output is completely isolated. The COM terminal is **NOT** connected to the signal or power supply COMMON terminal. (The contacts are rated at 5 A @ 250 VAC, 5 A @ 30 VDC, power factor = 1.)

NOTE: Pressing the TEST button (when enabled) tests the buzzer, analog output, and relays. The **Test function** may also be initiated **remotely** by **shorting the TEST + and TEST – terminals**. (The TEST – terminal is internally connected to the Analog COM terminal, and if desired, only one wire need be connected to the TEST + terminal if the power supply COM is used as the return signal path.) The TEST terminals should **only** be connected to a remote **switch or dry-contact**.

▲ CAUTION

Ensure no power is applied to the TEST terminals.

Operation

Warm-Up Mode

1. Verify that the detector is properly wired and all connections are tight.
2. Apply power.

The LCD display briefly indicates the software version number and begins a warm-up period of about 2 minutes. **During the warm-up, the alarm beeps three times, the LED flashes red, the signal output is fixed at 4 mA or 0 VDC, and the relays are off.**

After the warm-up period ends, the sensor reads the CO level, outputs the correct analog signal, and displays the value on the LCD.

Normal Mode

In normal operation, the sensor will measure the CO level and output a proportional value on the analog output, which is scaled to the default range of 0–300 ppm. The CO reading will also be displayed on the LCD. If alarm relays are installed, the present CO reading is compared to the setpoints and appropriate action is taken if an alarm condition exists. The status LED on the front cover will be green to indicate normal operation.

Alarm Mode

Automatic Alarm Reset (Default)

The CO reading is compared to setpoints for alarms, and if exceeded, the device enters Alarm mode.

The trip point, hysteresis (deadband), and delay time of each relay can be programmed via the menu. For example, Relay 1 defaults to a 50 ppm trip point, 10 ppm hysteresis, and 2 minute delay time. Relay 2 defaults to a 150 ppm trip point, 20 ppm hysteresis, and 2 minute delay time. All of these values can be changed via the menu. In the example for Relay 1, a timer is started when the CO level exceeds 50 ppm (the trip level). If the level drops below 50 ppm before 2 minutes (the delay time) has expired, then the relay is not activated. If the CO level exceeds 50 ppm for 2 minutes, then the relay is activated. The relay will remain activated until the CO level drops below 40 ppm (the trip level minus the hysteresis/deadband). This relay could be used to signal a “low alarm.” Relay 2 operates in the same manner and has independently programmable trip point, hysteresis, and delay time. This relay could be used to signal a “high alarm.” The LCD will indicate the Alarm mode details, and the LED will flash red.

The **buzzer alarm is enabled by default** with a 150 ppm trip point and 5 minute delay time. It can be programmed similarly to the relays. When the trip point is exceeded for a time longer than the delay time, the buzzer will sound until the CO level falls below the trip point. The buzzer operates independently of the relay alarms and can be disabled via the menu. **If enabled, pressing the TEST button will silence the buzzer (only) during Alarm mode.** Buzzer silence will hold only until that alarm condition is cleared.

Manual Alarm Reset

For this option, the alarm relays will activate the same way as described above but will not automatically reset to Normal Mode when the CO level drops below the trip level. In order to reset the relay alarms to Normal Mode, the user must also press the TEST switch on the front cover (or activate the remote TEST input) when the CO level is below the alarm level (minus the hysteresis/deadband).

The Manual Reset also applies to the buzzer alarm. If the buzzer alarm is active, pressing the TEST switch will temporarily silence the buzzer. But to reset the buzzer alarm to the Normal Mode, the CO level must have dropped below the value of the trip level (minus the hysteresis/deadband) when the TEST switch is pressed.

Test Mode

The Test function allows verification of the output and relay operation, and the Test time duration can be programmed via the menu. The Test mode function is **disabled by default** and must be enabled via the menu to later operate while in Normal mode. Test mode can only be activated while the device is in Normal mode (not if the device is in Fault, Alarm, or ReCal modes).

To initiate the Test function (if enabled) during Normal mode, either press and hold the TEST button for 1 second or activate it remotely by shorting the TEST + to TEST – (COM). This will cause the Status LED to blink red, the analog output to go to 100%, and both relays (if installed) to activate. The buzzer will also beep once every 15 seconds (if enabled), and the LCD will indicate Test mode and remaining time. The Test function will continue for 5 minutes (default), and then the device will reset to normal operation. **The Test function can be cancelled by pressing the TEST button a second time.**

Fault Mode

The Fault mode function is **disabled by default**, and it must be enabled via the menu to operate. The Fault function will monitor the CO sensor lifetime and **indicate when the CO sensor should be replaced**. If the device determines that the sensor has reached the end of its useful life and that replacement is necessary, it will enter Fault mode. This will cause the Status LED to blink red and the buzzer to beep once every 10 minutes. The LCD display will periodically show "Sensor Fault." The Fault mode can be disabled via the menu or enabled at any time. If enabled, and the device is in Fault mode, pressing the TEST button will "silence" the buzzer due to the Fault alarm only. Buzzer silence due to the Fault alarm will hold until the fault condition is reset via the menu. (The buzzer may still activate due to a CO setpoint alarm if enabled.)

▲ WARNING

All commercial CO sensors have a finite life. The life expectancy of these models is 5 to 7 years. They must be replaced periodically to ensure reliable operation in detecting conditions that are potentially hazardous to human health and safety.

ReCal (Recalibration) Mode

The ReCal mode function is **enabled by default** and must be disabled via the menu if it is not required. The ReCal function will monitor the device and indicate when the CO sensor should be recalibrated. If the device determines that the sensor requires recalibration, it will enter ReCal mode. This will cause the Status LED to blink red and the buzzer to beep once every 10 minutes. The LCD will periodically show "ReCal Required." If enabled, and the device is in ReCal mode, pressing the TEST button will silence the buzzer due to the ReCal alarm only. Buzzer silence due to the ReCal alarm will hold until the ReCal condition is reset via the menu. (The buzzer may still activate due to a CO setpoint alarm if enabled.)

Configuration

Operation parameters default to typical values but can be configured locally via the user menu using the LCD display and the three push-buttons on the circuit board. Any changes made are saved in non-volatile memory and are restored in case of a power loss. Only the menu items relevant to the device model and selections will be shown.

The menu can be accessed at any time after the warm-up mode. If there is 5 minutes of inactivity the menu will close and normal operation will continue. The TEST button has no effect when the menu is in use.

Menu item values are controlled by using the three buttons on the circuit board (ROLL, MENU, and SAVE). **To enter the menu, press and release the <MENU> key.** This will enter the menu Step 1, and pressing the <MENU> key a second time advances to Step 2. Each press of the <MENU> key advances the menu item. No values are saved or changed by using the <MENU> key.

The <ROLL> key is used to make changes to program values by **scrolling** through the available options. Holding the <ROLL> key pressed will scroll through some options at a faster rate.

When a value is changed, **press the <SAVE> key to save it to memory and advance to the next menu item.**

Press <MENU>

CO Range = 0–300 ppm

Press the <ROLL> key to scroll through the available options. The CO sensing range and output scale can be changed to 0 to 100 ppm, 0 to 150 ppm, 0 to 300 ppm, 0 to 400 ppm, or 0 to 500 ppm. Press the <SAVE> key to save any change. The factory default CO Range is 0 to 300 ppm.

Press <MENU>

Buzzer = Enable

Use the <ROLL> key to enable or disable the buzzer alarm. When disabled, the buzzer will not sound if the buzzer trip point is exceeded. The buzzer will still beep on startup and will still beep for a fault alarm (if enabled). Press <SAVE> to save the setting. The factory default is Enable.

Press <MENU>

Buzzer Trip = 150

Use the <ROLL> key to scroll through the available options. The buzzer alarm trip point may be set from 0 to 500 ppm in 10 ppm increments. Press <SAVE> to save the setting. The factory default is 150 ppm. (This item will not be shown if the buzzer is disabled.)

Press <MENU>

Buzzer Del = 5Min

Use the <ROLL> key to scroll through the available options. The buzzer delay may be set from 0 to 10 minutes in 1 minute increments. Press <SAVE> to save the setting. The factory default is 5 minutes. (This item will not be shown if the buzzer is disabled.)

Press <MENU>

Buzzer Test = OFF

Use the <ROLL> key to enable the buzzer (ON) during test mode or disable it (OFF). Press <SAVE> to save the setting. The factory default is Off. (This item will not be shown if the buzzer is disabled.)

Press <MENU>

Relay 1 TRIP = 50

Use the <ROLL> key to scroll through the available options. The Relay 1 alarm trip point may be set from 20 to 500 ppm in 10 ppm increments. Press <SAVE> to save the setting. The factory default is 50 ppm. (This item will not be shown if Relay 1 is not installed.)

Press <MENU>

Relay 1 Hyst = 10

Use the <ROLL> key to scroll through the available options. The Relay 1 hysteresis (deadband) may be set from 10 to 100 ppm in 5 ppm increments. Press <SAVE> to save the setting. The factory default is 10 ppm. Note that the maximum value may be limited by the trip-point value. (This item will not be shown if Relay 1 is not installed.)

Press <MENU>

Relay 1 DEL = 2MIN

Use the <ROLL> key to scroll through the available options. The Relay 1 delay may be set from 0 to 10 minutes in 1 minute increments. Press <SAVE> to save the setting. The factory default is 2 minutes. (This item will not be shown if Relay 1 is not installed.)

Press <MENU>

Relay 1 Test = OFF

Use the <ROLL> key to enable Relay 1 (ON) during test mode or disable it (OFF). Press <SAVE> to save the setting. The factory default is Off. (This item will not be shown if Relay 1 is not installed.)

Press <MENU>

Relay 2 Trip = 150

Use the <ROLL> key to scroll through the available options. The Relay 2 alarm trip point may be set from 20 to 500 ppm in 10 ppm increments. Press <SAVE> to save the setting. The factory default is 150 ppm. (This item will not be shown if Relay 2 is not installed.)

Press <MENU>

Relay 2 Hyst = 20

Use the <ROLL> key to scroll through the available options. The Relay 2 hysteresis (deadband) may be set from 10 to 100 ppm in 5 ppm increments. Press <SAVE> to save the setting. The factory default is 20 ppm. Note that the maximum value may be limited by the trip-point value. (This item will not be shown if Relay 2 is not installed.)

Press <MENU>

Relay 2 Del = 2Min

Use the <ROLL> key to scroll through the available options. The Relay 2 delay may be set from 0 to 10 minutes in 1 minute increments. Press <SAVE> to save the setting. The factory default is 2 minutes. (This item will not be shown if Relay 2 is not installed.)

Press <MENU>

Relay 2 Test = OFF

Use the <ROLL> key to enable Relay 2 (ON) during test mode or disable it (OFF). Press <SAVE> to save the setting. The factory default is Off. (This item will not be shown if Relay 2 is not installed.)

Press <MENU>

TestMode = Disable

Use the <ROLL> key to disable or enable the test mode. The factory default is Disable. When disabled, the TEST button or TEST input will not initiate the test function. When enabled, pressing the TEST button or shorting the TEST input will initiate the test function. Press <SAVE> to save the setting.

Press <MENU>

TestMode = Time 5

Use the <ROLL> key to scroll through the available options. The test mode operating time may be set from 1 to 15 minutes in 1 minute increments. Press <SAVE> to save the setting. The factory default is 5 minutes. This item sets how long the test mode will operate when the TEST button is pressed. (This item is not shown if the test mode is disabled.)

Press <MENU>

Fault Md = Disable

Use the <ROLL> key to select Enable, Disable, or Reset. When disabled, the device will not sound the buzzer or provide LCD and status LED indication when the sensor life is exceeded. When enabled, the fault alarm will activate to indicate the sensor life is exceeded. Press <SAVE> to save the setting. The factory default is Disable. If it is set to Reset and <SAVE> is pressed, then the fault condition is cleared, the life-time timer is reset and fault mode is set back to its default (Disable). It may be enabled again.

⚠ WARNING

All commercial CO sensors have a finite life. The life expectancy of these models is 5 to 7 years. They must be replaced periodically to ensure reliable operation in detecting conditions that are potentially hazardous to human health and safety.

Press <MENU>

Fault Md Time = 3yr

Use the <ROLL> key to set the fault mode timer to 3, 4, 5, or 6 years. The factory default is 3 years. Press <SAVE> to save the setting. If the desired time has already been exceeded, then it cannot be selected. (This item is not shown if the fault mode is disabled.)

Press <MENU>

ReCal Md = Enable

Use the <ROLL> key to select Enable, Disable, or Reset. When disabled, the device will not sound the buzzer or provide LCD and status LED indication when the sensor requires recalibration. When enabled, the ReCal alarm will activate to indicate the sensor requires recalibration. Press <SAVE> to save the setting. The factory default is Enable. If set to Reset and <SAVE> is pressed, then the ReCal condition is cleared, the ReCal timer is reset, and ReCal mode is set back to its default (enabled). This can be used if the CO sensor is required to be recalibrated at known intervals.

Press <MENU>

ReCal Md Time = 1yr

This is used to set the CO sensor recalibration interval. Use the <ROLL> key to set the ReCal mode timer to 1, 2, or 3 years. The default is 1 year. Press <SAVE> to save the setting. (This item is not shown if the ReCal mode is disabled.)

Press <MENU>

Alarm Md = Auto

Use the <ROLL> key to set the Alarm Mode to Auto or Manual. The factory default is Auto. This setting controls how the relay alarms and the buzzer alarm resets back to Normal mode. For the Auto setting, the device will reset the alarms automatically once the CO level drops below the set alarm thresholds. For the Manual setting, the CO level must be below the alarm thresholds AND the user must press the TEST switch to reset the alarms. Press <SAVE> to save the setting.

Press <MENU>

0 Filter = Enable

Use the <ROLL> key to enable or disable the zero filter. When enabled, the device will filter low ppm readings, such that 0 to 5 ppm CO will display and output 0 ppm. When disabled, 0–5 ppm will display and output actual 0–5 ppm. Press <SAVE> to save the setting. The factory default is Enable. **This should be set to Disable when doing a ZERO gas calibration.**

Press <MENU>

Display = CO Value

Use the <ROLL> key to toggle the setting to either CO Value or Status. When set to CO Value, the actual ppm value of the CO reading will be displayed on the LCD. When set to Status, the ppm value will not be displayed but only “CO Detector” or the device operating status (e.g., Test). Press <SAVE> to save the setting. The factory default is CO Value.

Press <MENU>

BackLite = Enable

Use the <ROLL> key to enable or disable the LCD backlight. The backlight is always on when enabled and always off when disabled. Press <SAVE> to save the setting. The factory default is Enable.

Press <MENU>

Out Type = 0–5 VDC

Use the <ROLL> key to toggle the voltage output type to either 0–5 VDC or 0–10 VDC. Press <SAVE> to save the setting. The factory default is 0–5 VDC. **This item is only shown if the board’s output switch is in the VOLT position. The output type can only be changed by temporarily disconnecting power to the unit.**

Press <MENU>

Output Test = OFF

This can be used to test the output signal. Use the <ROLL> key to scroll through the available options. The analog output and display depends on the output type configuration.

- For 4–20 mA output, the setting options are OFF/4/8/12/16/20 mA.
- For 0–5 VDC output, options are OFF/0/1/2/3/4/5 VDC.
- For 0–10 VDC output, options are OFF/2/4/6/8/10 VDC.

Calibration

The sensor may also be calibrated or verified with CO gas as needed. This requires a field calibration kit consisting of a bottle of gas (e.g., 250 ppm CO), a tank pressure regulator with flow restrictor, and the necessary tubing to supply the gas into the sensor. Calibration can be done at 68–80° F (20–27° C). The device cover must be opened to perform an actual calibration. Open the cover to access the port.

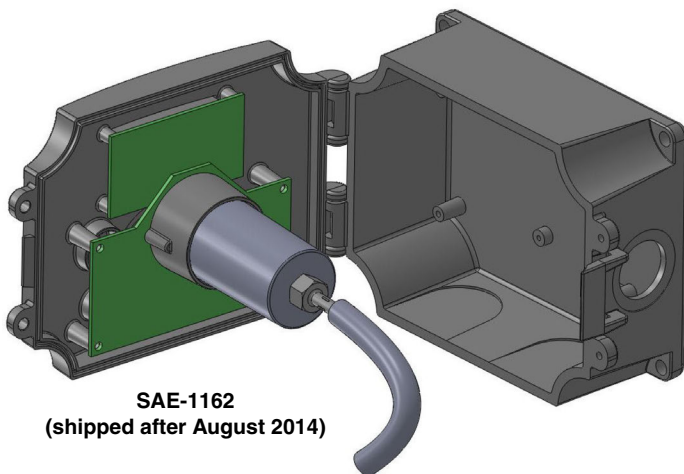

NOTE: The sensor must be continuously powered for at least 1/2 hour prior to calibration.

NOTE: If the “0 Filter” option is enabled, disable it in the menu temporarily for the calibration. (See [Configuration on page 5](#).)

NOTE: The ZERO and SPAN potentiometers are located on the edge of the sensor board.

NOTE: Attach the tubing as described and illustrated above.

NOTE: Properly recalibrating the **SAE-1162 duct** sensors **shipped before August 2014** is more difficult. For those earlier units with different sensor boards (without the gas tube port receptacle), it is recommended to disable the ReCal mode, set the Fault Mode time to 3 years, and then replace the SAE-1162 with a new or factory-recalibrated unit when the time has expired.

1. Calibrate the sensor first in clean air with no CO gas present by adjusting the ZERO potentiometer on the sensor board until a 4 mA (or 0 VDC) output is obtained and the LCD displays 0 ppm.
2. Turn the regulator on/off knob fully off, attach it to the 250 ppm gas bottle, and firmly tighten the regulator by hand.
3. Moisten the sponge and squeeze out any excess water. Place the sponge in the cap so that it will not touch the sensor but does not plug the hole in the side of the cap. (The sponge will ensure the gas is in the right humidity range.)
4. Attach the cap to the port over the sensor. (If the gas cap is too loose on the sensor port, wrap electrical tape around the cap.)
5. Slowly turn the valve knob on the regulator to let the gas begin flowing. The regulator will restrict the flow rate to the specified 200 ml/min.
6. Wait for 5 minutes and then adjust the SPAN potentiometer on the sensor board until the LCD reads 250 ppm (or the CO concentration of the gas cylinder).
7. Close the valve on the tank.
8. Calibration is complete. Reset the ReCal Mode if it is enabled.

Accessories

- XEE-6111-050 Transformer, 120-to-24 VAC, 50 VA, **single**-hub
- XEE-6112-050 Transformer, 120-to-24 VAC, 50 VA, **dual**-hub

Maintenance

Careful installation will also ensure long-term reliability and performance. Remove dust as necessary from holes. Clean with a soft, damp cloth and mild soap.

⚠ WARNING

All commercial CO sensors have a finite life. The life expectancy of these models is 5 to 7 years. They must be replaced periodically to ensure reliable operation in detecting conditions that are potentially hazardous to human health and safety.

Important Notices

The material in this document is for information purposes only. The contents and the product it describes are subject to change without notice. KMC Controls, Inc. makes no representations or warranties with respect to this document. In no event shall KMC Controls, Inc. be liable for any damages, direct or incidental, arising out of or related to the use of this document.

More Information

For specifications, see the [SAE-1162 Data Sheet](#) on the KMC web site (www.kmcccontrols.com).

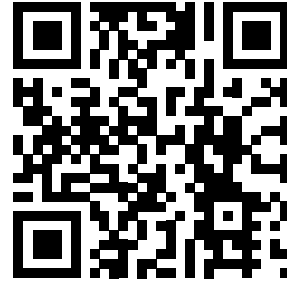

KMC Controls, Inc.
19476 Industrial Drive
New Paris, IN 46553
574.831.5250
www.kmcccontrols.com
info@kmcccontrols.com