

Installation Guide

Mounting

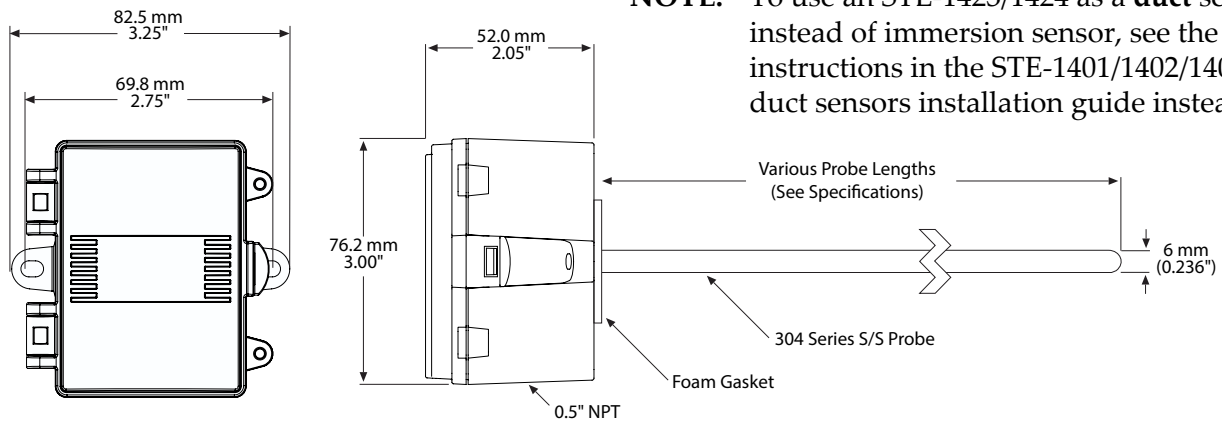

NOTE: To use an STE-1423/1424 as a **duct** sensor instead of immersion sensor, see the instructions in the STE-1401/1402/1404/1405 duct sensors installation guide instead.

Immersion probes measure the temperature inside pipes carrying liquid or steam and are installed in a 304 stainless-steel thermowell. Mount the thermowell horizontally or with the open end facing down (to allow any condensation to drain). Select an appropriate length (4 or 6 inches of sensor probe and thermowell) and position the thermowell to prevent contact with the inner surface of the opposite side of the pipe.

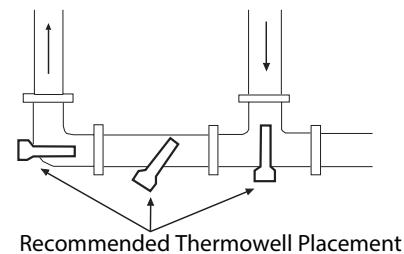

1. Install the pipe fittings required, by local code, for a 1/2" NPT thermowell into the dry/drained pipe. If the system is pressured, use a hot tap.
2. Install the thermowell. (See the Accessories section.)
3. Fill the thermowell with thermal compound to ensure complete conductivity from well to probe.
4. Open the sensor cover by pulling slightly on the latch on the right side of the enclosure while pulling on the cover.
5. From inside the enclosure, push the probe as far as it will go into the thermowell.

NOTE: As it is inserted into the thermowell, the probe can slide within its collar on the enclosure.

6. Tighten the set screw on the thermowell to secure the probe.
7. For the cable leading to the building automation system controller, attach conduit to the 1/2" NPT threaded connection hole that is provided in the bottom of the enclosure as needed.

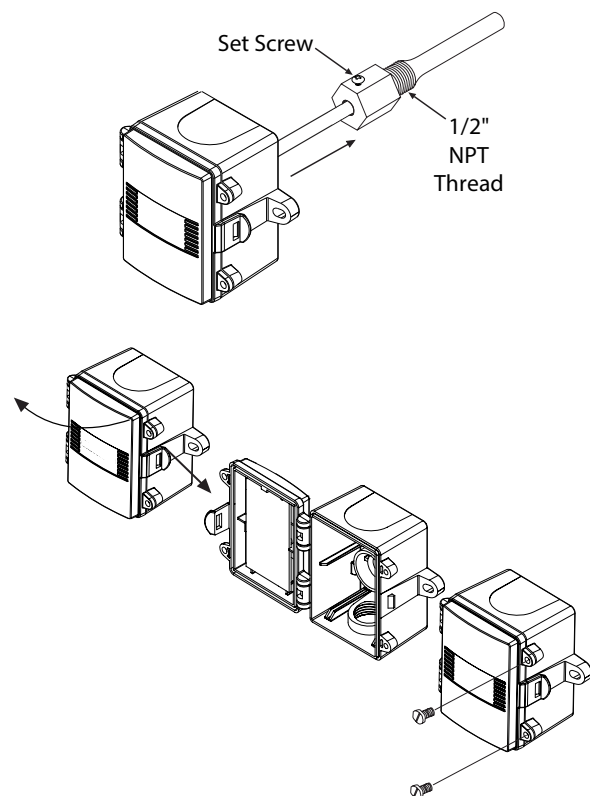

Connections and Wiring

NOTE: Use 18 to 24 AWG shielded wiring for all connections. Do not locate the device wires in the same conduit with wiring used to supply inductive loads such as motors. Make all connections in accordance with national and local codes.

1. Bring the cable from the controller through the bottom hole.
2. Make connections to the two wire leads with either butt-splices or solder. Using wire nuts is **not** recommended.

NOTE: The two-wire sensor is not polarity sensitive.

NOTE: Plug the conduit with sealant to prevent air infiltration.

3. Swing the door closed until securely latched.
4. If desired for added security, install the two (provided) screws in the door's integrated screw tabs.

Accessories

HMO-4532	Thermal compound (1 oz.) for thermowells
HMO-4545	4-inch 304 stainless-steel thermowell (for the STE-1423)
HMO-4546	6-inch 304 stainless-steel thermowell (for the STE-1424)

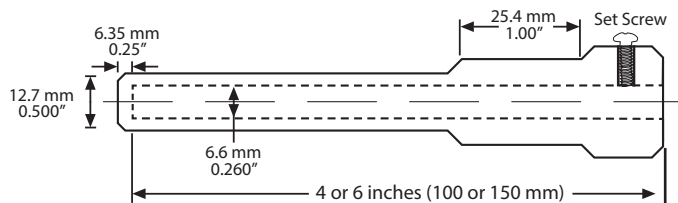

NOTE: STE-1423/1424 immersion sensors replace older STE-1421/1422 sensors used with (threaded) HMO-4534/4544 thermowells. When replacing an STE-1421/1422 sensor with an STE-1423/1424, replace the thermowell with an HMO-4545/4546.

Specifications

Probe Lengths

STE-1423	4 inches (100 mm)
STE-1424	6 inches (150 mm)

Sensor Type III thermistor, 10K ohm @ 77° F (25° C)

Probe Sensing Range

-40 to 212° F (-40 to 100° C)

Ambient Operating Range

-40 to 122° F (-40 to 50° C),
5 to 95 % RH noncondensing

Enclosure

UL94-V0, IP65 (NEMA 4X),
ABS

Wiring

PVC insulated, 22 AWG, wire leads

Maintenance

No routine maintenance is required. Each component is designed for dependable, long-term reliability and performance. Careful installation will also ensure long-term reliability and performance.

More Information

For **troubleshooting, controller configuration, and other information**, see the [Type III Sensors Applications Guide](#) on the KMC web site. For **additional information**, see the [STE-1400 Series Data Sheet](#) on the KMC web site.

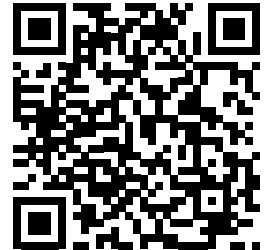

Important Notices

The KMC logo and KMC Controls are registered trademarks of KMC Controls, Inc. All rights reserved. No part of this publication may be reproduced, transmitted, transcribed, stored in a retrieval system, or translated into any language in any form by any means without the written permission of KMC Controls, Inc.

The material in this document is for information purposes only. **The contents and the product it describes are subject to change without notice.** KMC Controls, Inc. makes no representations or warranties with respect to this document. In no event shall KMC Controls, Inc. be liable for any damages, direct or incidental, arising out of or related to the use of this document.

KMC Controls, Inc.

19476 Industrial Drive

New Paris, IN 46553

574.831.5250

www.kmcccontrols.com; info@kmcccontrols.com