

Installation Guide

Mounting

NOTE: To assemble a quick-mount "V" actuator on a valve body, see the [HPO-5074 Installation Guide](#) on the KMC web site.

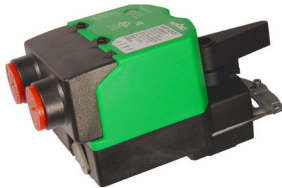

MEP-4x5xV Actuator



VFB-43 Series Valve Body

1. Clean the lines upstream from the valve. Remove any debris larger than 1/16 inch (1.6 mm).
2. Align the valve's flow indicator with the system flow.
3. Mount the valve so the actuator is positioned over valve.

CAUTION

To prevent condensation from dripping onto the actuator housing, mount the valve with the actuator in the upright position or, at most, at a 45° angle.

4. Seal valves with approved pipe sealant.
5. Using two wrenches, secure the valve to the pipe. Torque should not exceed 75 ft-lb. (102 N•m).
6. Eliminate air from the system to keep the valves full of fluid during operation.

NOTE: If the system experiences large amounts of debris, steps should be taken to keep the system clean, such as a 20 mesh strainer installed upstream of the valve.

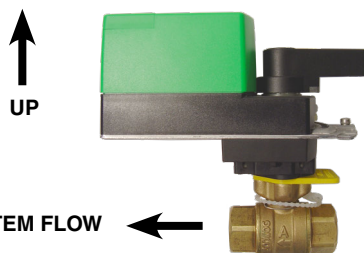

ACTION:
Full CW = Valve Closed
Full CCW = Valve Open

CAUTION

Using mineral oil lubricants or other incompatible substances in system fluids may damage EPDM rubber seals in valves. Before using any lubricant or additive in a water or ethylene glycol base, consult the substance manufacturer for compatibility with EPDM (Ethylene Propylene Diene Monomer).

Wiring

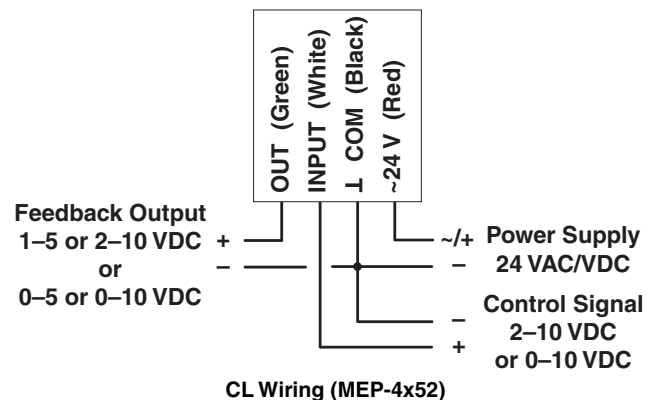
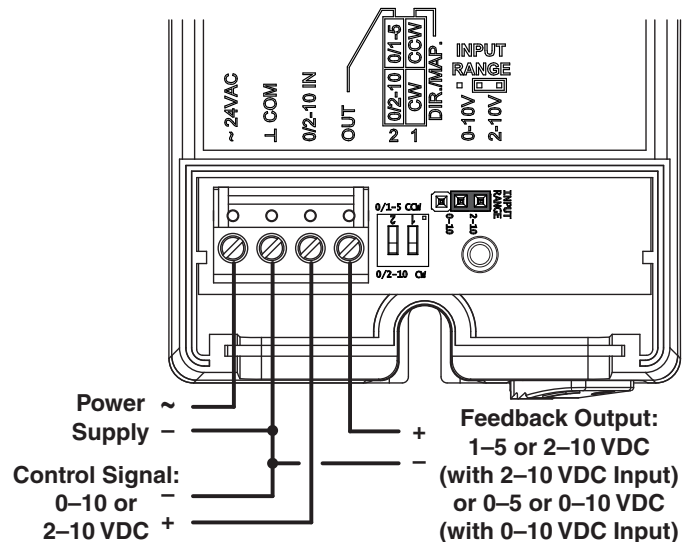

NOTE: The installed actuator model is indicated by the last two digits of the VEB valve model number (e.g., VEB-43xxxx**CK** has an MEP-4002V actuator) and the last three digits of the older VEP valve model number (e.g., VEP-45xxx**745** has an MEP-4002 actuator). **For wiring and other information about tri-state and other actuators no longer sold mounted on these valves, see the respective actuator's installation guide on the KMC web site.**

For additional instructions on wiring, feedback selector, and actuator/signal range reset (auto-mapping), see the [MEP-4000/4800 Series Installation Guide](#) or (fail-safe) [MEP-4200/4500/4900 Series Installation Guide](#).

Operation

After the mechanical and electrical installations have been completed, cycle the actuator to verify the direction of rotation for normal operation and fail-safe if so equipped.

Maintenance

No routine maintenance is required. Each component is designed for dependable, long-term reliability, and performance. Careful installation will also ensure long-term reliability and performance.

More Information

For models, specifications, and additional information, see the [VEB-43/VFB-43 Series Data Sheet](#) on the KMC web site.

For **non-fail-safe** wiring, auxiliary switches, feedback/direction selectors, actuator/signal range reset (auto-mapping), and other information, see the [MEP-4000/4800 Series Installation Guide](#).

For **fail-safe** wiring, auxiliary switches, feedback/direction selectors, actuator/signal range reset (auto-mapping), and other information, see the [MEP-4200/4500/4900 Series Installation Guide](#).

For information on assembling a quick-mount "V" actuator on a valve body, see the [HPO-5074 Installation Guide](#).

Important Notices

The material in this document is for information purposes only. The contents and the product it describes are subject to change without notice. KMC makes no representations or warranties with respect to this document. In no event shall KMC be liable for any damages, direct or incidental, arising out of or related to the use of this document.

KMC Controls, Inc.
19476 Industrial Drive
New Paris, IN 46553
574.831.5250
www.kmcccontrols.com
info@kmcccontrols.com